

SAN FRANCISCO BAY AREA RAPID TRANSIT DISTRICT

2150 Webster Street, Oakland, CA 94612 • P.O. Box 12688, Oakland, CA 94604-2688
510-464-6000

**NOTICE OF MEETING AND AGENDA
BART Bicycle Advisory Task Force (BBATF)**

August 7, 2023
6:00 p.m. – 8:00 p.m.

BBATF Members: Jon Spangler (Chairperson), Rick Goldman (Vice Chairperson), Tyler Morris (Secretary), Marc Hedlund, Francisco Hulse, Jeremiah Maller, Phoenix Mangrum, Francisco Muñoz, and Bill Pinkham.

Chairperson Jon Spangler has called a meeting of the BART Bicycle Advisory Task Force on August 7, 2023, at 6:00 p.m. Public participation for this meeting will be via teleconference only. Presentation materials will be available via Legistar at <https://bart.legistar.com>

You may join the Task Force meeting via Zoom by calling (833) 548-0282 and entering access code 876 9805 3757; logging into Zoom.com and entering access code 876 9805 3757; or typing the following Zoom link into your web browser: <https://us06web.zoom.us/j/87698053757>

If you wish to make a public comment:

- 1) Submit written comments via email to hmaddox@bart.gov using “public comment” as the subject line. Your comment will be provided to the Task Force and will become a permanent part of the file. Please submit your comments as far in advance as possible. Emailed comments must be received before noon on August 4, 2023 in order to be included in the record.
- 2) Call (833) 548-0282, enter access code 876 9805 3757, dial *9 to raise your hand when you wish to speak, and dial *6 to unmute when you are requested to speak; log into Zoom.com, enter access code 876 9805 3757 and use the raise hand feature; or join the Task Force meeting via the Zoom link (<https://us06web.zoom.us/j/87698053757>) and use the raise hand feature.

Public comment is limited to two (2) minutes per person.

BART provides services/accommodations upon request to persons with disabilities and individuals who are limited English proficient who wish to address Committee matters. A request must be made between one and five days in advance of Board/Committee meetings, depending on the service requested. Please contact the Office of the District Secretary at (510) 464-6083 for information.

SAN FRANCISCO BAY AREA RAPID TRANSIT DISTRICT

2150 Webster Street, Oakland, CA 94612 • P.O. Box 12688, Oakland, CA 94604-2688
510-464-6000

AGENDA

1. Self-Introductions of Members, Staff, and Guests: All. (*For Information*) 5 min.
2. General Discussion and Public Comment: Jon Spangler. (*For Information*) 5 min.
3. Approval of June 2023 BBATF Minutes: Jon Spangler. (*For Action*) 5 min.
4. Approval of BBATF Member Applications: (*For Action*) 15 min.
 - Sebastian Harper – San Francisco County
 - Cedar Makhijani – At-large
 - Ashley Von Edge – At-large
5. North Berkeley Transit-Oriented Development Bicycle Access Update: Rachel Factor, BART Station Planning. (*For Information*) 15 min.
6. El Cerrito Plaza Transit-Oriented Development Bicycle Access Update and Letter from BBATF: Rachel Factor, BART Station Planning. (*For Information and Action*) 25 min.
7. Safe Routes to BART Grant Program Round 2 Awards: Rachel Factor, BART Station Planning. (*For Information*) 15 min.
8. BART to Silicon Valley Phase II Extension Santa Clara Valley Transportation Authority (VTA) Responses and Letter from BBATF: Jon Spangler. (*For Discussion and Action*) 15 min.
9. BART Bike Program Updates: Heath Maddox, BART Customer Access. (*For Information*) 15 min.
10. Future Agenda Items: All. (*For Discussion*) 5 min.

BART Bicycle Advisory Task Force (BBATF)

Meeting Minutes

June 5, 2023 6:00 p.m. – 8:00 p.m.

BBATF Members: Jon Spangler (Chair), Rick Goldman (Vice Chair), Jeremiah Maller, Phoenix Mangrum, Bill Pinkham, Francisco Muñoz, Tyler Morris (Secretary).

Chair Jon Spangler has called a meeting of the BART Bicycle Advisory Task Force on June 5, 2023, at 6:00 p.m. via Zoom link <https://us06web.zoom.us/j/81666287147>

Meeting called to order at 6:01 p.m. by Chair Jon Spangler

In attendance:

BBATF: Jon Spangler (Chair), Jeremiah Maller, Bill Pinkham, Francisco Muñoz, Tyler Morris (Secretary), Phoenix Mangrum

BART Staff: Heath Maddox (Liaison), Kamala Parks, Alex Walker

BART Directors: Robert Raburn

Guests: Francisco Hulse, Adriano Rothschild (VTABSV), Ashley Von Edge (SFBC), Lauren Ledbetter (VTA), Marc Hedlund, Stephen Marea, Hunter Oatman-Stanford (Caltrans), Patricia S.(BPAC), Sebastian Harper, Cedar Makhijani.

Absent: Rick Goldman (Vice Chair)

Agenda with Minutes follows as:

1. 6:01p.m. Self-introductions of members, staff, and guests: All. (For Information) 5 min.
 1. Jon Spangler welcomed guests and colleagues
2. 6:11p.m. General discussion and public comment: Jon Spangler. (For Information) 5 min.
 1. Tyler M gave a shout out to Bike to Where Ever Day
 2. Marc H commented on bike access through the TOD at North Berkeley BART station
 3. Bill P commented about the Ohlone Greenway at North Berkeley
3. 6:17p.m. Approval of April 3rd, 2023 BBATF minutes: Jon Spangler. (For Action) 5 min.
 1. Jon Spangler moved to approve minutes. Bill P seconded the motion
 2. Phoenix Mangrum not present yet for vote
 3. Unanimously approved
4. 6:19p.m. Appointment of BBATF Members (For Action) 15 min.
 1. Jeremiah Maller – Santa Clara County
 1. Francisco M motioned to approve, and Tyler M seconded.

2. Approved with Jeremiah Maller abstaining
 3. Phoenix Mangrum not present yet for vote
 2. Sebastian Harper – San Francisco County (not yet present)
 1. Moved to August agenda
 3. Marc Hedlund – At-large
 1. Bill P moved to approve and Jon S seconded
 2. Phoenix Mangrum not present yet for vote
 3. Approved unanimously
 4. Francisco Hulse – San Francisco County
 1. Stephen M moved to approve membership and Bill P seconded
 2. Francisco M abstained from voting
 3. Phoenix Mangrum not present yet for vote
 4. Motion approved
 5. Stephen Marea – Alameda County
 1. Tyler M moved to approve the membership, and Francisco M seconded
 2. Phoenix Mangrum not present yet for vote
 3. Unanimously approved
 6. Nomination of Cedar Makhijani (At-large) (not yet at meeting).
 1. Moved to August agenda
5. 6:33p.m. BART to Silicon Valley Phase II Extension Update: Adriano Rothschild & Grant Brokl, Santa Clara Valley Transportation Authority. (For Information and Action) 70 min.
1. Adriano introduces the presentation and asks for questions at the end
 1. 6 mile system extension via single bore
 2. 1 mile above ground track and 5 mile below ground track
 3. Early construction commences late 2023
 4. Design phase extends through 2024
 5. Contractor innovation allows for side-by-side track design and wider tunnel diameter
 6. Vertical accessibility has been shortened from original design
 7. Fare gates at street entrance
 8. Cargo bikes will fit in elevators
 9. 6,700-27,900 daily riders projected for the various stations along the extension
 10. City of San Jose Better Bike Plan 2025 will aim to increase bike access throughout the extension line area
 11. Stair channels will be integrated at the Little Portugal, Downtown, and Diridon stations
 12. May 4th 2023 Central Bikeway was approved to enhance bike transit access

1. 10 mile separated bike path running East to West
13. Jon S asked what kind of class is the Central Bike Way
 1. Lauren L stated its Class 4 at sidewalk level and street level
 2. Francisco M mentioned that a slide better acknowledging the deeper vertical access at some stations would have been nice for the bike community
 3. Francisco M asked why the Downtown station and Little Portugal station have the same number of bike parking spots
 4. Bill P brought up worries about the full funding of the project and asked what sources have been identified for that funding
 1. There is only ~~around~~ a small percentage of funding gap that currently exists and doubts about that funding gap remaining are low on VTA's perspective
 5. Marc H urges having as many double sided elevators since design is relying on elevators for bike access to overcome the deep vertical access
 6. Marc H comment: bike cages are more conducive for cargo bikes vs. lockers
 7. Francisco H asked for clarification about some acronyms and terms contained in the presentation
 8. Jeremiah M asked why there is so many vehicle parking spots at certain stations
 1. There are some State/Federal guidelines governing vehicle parking spaces
 2. VTA is considering future development uses with sites for vehicle parking
 9. Tyler M asked what the construction timeline of the Central Bike Way project is in relation to BART BSV2 extension construction
 1. VTA is in early design phase and has not finalized a project projected timeline
 10. Jon S asked a series of questions about stair width feasibility to accommodate bikes if elevators are out of order; stairwell access, and financial costs to add a North side entrance to Diridon station and a south side entrance to the Downtown station.
6. 7:48p.m. BART Bike Program Updates: Heath Maddox, BART Customer Access. (For Information) 10 min.
 1. Heath M shares his graph showing correlation between bike parking and BART ridership
 2. Bike-share users accessing BART has risen dramatically
 3. Heath M shared the executive summary of the 2022 BART customer satisfaction survey
 4. Heath M will email members some project links and details for an informational dive on the Iron Horse Trail project
7. 8:07p.m. Future Agenda Items: All (For Discussion) 10 min.
 1. New Members

2. Heath M project updates
3. SAFE Routes to BART
4. Prior April agenda minutes items
5. Bill P: advocate for better links from BART stations to the BayTrail
6. [Francisco M?] Time-boxing post presentation comments
7. Director Raburn: Update on progress closing BART station network gaps (Network Gap Studies of 18 stations, 2017-20) <https://www.bart.gov/about/planning/station-access>

Meeting adjourned at 8:14p.m. by Chair Jon Spangler

Next meeting is called for by Chair Jon Spangler on August 7th, 2023 at 6:00p.m.

BBATF Members (terms are three years)

LAST UPDATED = 7/27/23

Code: Term Year-County-Representative

Abbreviations: SF = San Francisco

AL = Alameda

CC = Contra Cost

SM = San Mateo

SC = Santa Clara

BAO = bicycle advocacy organization

BAC = bicycle advisory committee

OCCUPIED
VACANT
PENDING
NEEDS RENOMINATION

BAC	BAO	BAC	BAO
2022	2023	2024	2024
2-SF-Tyler Morris	3-SF-Tyler Morris	1-SF-	
1-SF-Jeremiah Malller	2-SF-Francisco Hulse	3-SF-Francisco Hulse	
3-SF-VACANT	1-SF- Sebastian Harper	2-SF- Sebastian Harper	3-SF- Sebastian Harper
2-AL-Phoenix Magnum	3-AL-Phoenix Magnum	1-AL-	
1-AL-Jon Spangler	2-AL-Jon Spangler	3-AL-Jon Spangler	
3-AL-Jianhan Wang	1-AL-VACANT	2-AL-VACANT	3-AL-VACANT
2-CC-Bill Pinkham	3-CC-Bill Pinkham	1-CC-	
1-CC-VACANT	2-CC-VACANT		
3-CC-VACANT	1-CC-VACANT		
2-SM-VACANT	3-SM-VACANT		
1-SM-VACANT	2-SM-VACANT		
3-SM-VACANT	1-SM-VACANT		
2-SC-VACANT	3-SC-VACANT		
1-SC-Francisco Munoz	2-SC-Francisco Munoz	3-SC-Francisco Munoz	
3-SC-VACANT	1-SC-Jeremiah Maller	2-SC-Jeremiah Maller	3-SC-Jeremiah Maller
2-ALG-VACANT	3-ALG-Marc Hedlund	3-ALG-	
1-ALG-Rick Goldman	2-ALG-Rick Goldman	3-ALG-Rick Goldman	
3-ALG-VACANT	1-ALG-Cedar Makhijani	2-ALG-Cedar Makhijani	3-ALG-Cedar Makhijani

SEBASTIAN HARPER

BART Bicycle Advisory Task Force Membership Application

The BART Bicycle Advisory Task Force (BBATF) advises the BART Board on bicycle-related matters. The BBATF meets on the first Monday of even-numbered months from 6:00 to 8:00 PM in downtown Oakland at a BART-accessible location. Task force members are expected to attend all/most meetings. More information about the purpose of the task force can be found here: <http://www.bart.gov/about/bod/advisory/bicycle>

Please email application to:

Heath Maddox
BART Bike Program Manager
hmaddox@bart.gov
415-728-1352

(1) How frequently do use BART or other public transit?

- 5 days a week or more
- 1-4 days a week
- A couple times a month
- Once a month or less

(2) How often do you use a bicycle to get to and from BART or other public transit?

- Always
- Most of the time
- Occasionally
- Never

(3) How often do you use a bicycle to commute to work or for daily transportation?

- Always
- Most of the time
- Occasionally
- Never

(4) What motivates you to want to serve on the BBATF?

(5) What perspectives, skills, or experiences you would bring to the BBATF?

(6) Are you involved with any organizations or advisory boards related to public transit or bicycling?

No, but my enthusiasm and fresh perspective are just what the BBATF needs

Yes, please describe:

(7) Could you commit to attending most or all of the BBATF's 6 meetings each year?

Yes No

Not sure: _____

(8) How did you hear about the BBATF?

(9) What questions do you have about the role of the BBATF or being a BBATF member?

(10) Your information:

Name

County of Residence

County of Employment

Email and/or phone

Heath Maddox

From: Christopher White <[REDACTED]>
Sent: Monday, March 6, 2023 12:55 PM
To: Heath Maddox
Cc: Janelle Wong; Sebastian Harper; Jon Spangler
Subject: Re: FW: BART Bicycle Advisory Task Force Membership Application

Great, thanks for the context, Heath. Sebastian, we're very glad to nominate you for the position, and appreciate your willingness to volunteer your time and expertise!

--

Christopher White

Deputy Director

New number (phone or text): (415) [REDACTED] [REDACTED]

Pronouns: he, him, his

[San Francisco Bicycle Coalition](#)

Promoting the Bicycle for Everyday Transportation

[1720 Market St.](#)

[San Francisco, CA 94102](#)



On Mon, Mar 6, 2023 at 10:40 AM Heath Maddox <hmaddox@bart.gov> wrote:

Hi Christopher,

Yes, this is typically the way things work for the BART Bike Task Force. Prospective members generally express interest and/or apply directly and then I inform them of the full process, and if they haven't yet applied, I provide an application and, depending upon where they live or work and what seat would be most appropriate, I reach out to the appropriate nominating body. There are a lot of seats and always a good number of vacancies on the BBATF, so we've never had to turn anyone away since I've been involved (~5 years), although sometimes it's necessary to point someone to an at-large seat or have them use the county they work in instead of their home county.

Two of San Francisco's three BBATF seats are currently vacant. While SF seats have been historically easier to fill than Contra Costa, San Mateo or Santa Clara Counties, I'm seeing that at least one of the SF seats has been vacant since Tracy Jacks resigned at the end of 2020, so since Sebastian's application does seem strong, I think it's best to move forward with that application now. The BBATF also currently has two at-large vacancies, so if we do end up filling all three of SF's seats in the near future and then miraculously find ourselves with a fourth SF applicant who checks all the boxes for diversity of background and lived experience in addition to the other qualifications, we'd most likely be able to offer this individual an at-large seat.

CEDAR MAKHIJANI

BART Bicycle Advisory Task Force Membership Application

The BART Bicycle Advisory Task Force (BBATF) advises the BART Board on bicycle-related matters. The BBATF meets on the first Monday of even-numbered months from 6:00 to 8:00 PM in downtown Oakland at a BART-accessible location. Task force members are expected to attend all/most meetings. More information about the purpose of the task force can be found here: <http://www.bart.gov/about/bod/advisory/bicycle>

Please email application to:

Heath Maddox
BART Bike Program Manager
hmaddox@bart.gov
415-728-1352

(1) How frequently do use BART or other public transit?

- 5 days a week or more A couple times a month
 1-4 days a week Once a month or less

(2) How often do you use a bicycle to get to and from BART or other public transit?

- Always Occasionally
 Most of the time Never

(3) How often do you use a bicycle to commute to work or for daily transportation?

- Always Occasionally
 Most of the time Never

(4) What motivates you to want to serve on the BBATF?

I'm passionate about transportation and bikes, and I think that combining the two is one of our best tools in the fight to reduce car trips and make our cities more sustainable. I rarely ride BART without my bike, and I think that BART does a lot right, but still has a lot of room to grow.

(5) What perspectives, skills, or experiences you would bring to the BBATF?

I'm a bike commuter and regular BART (with bike) user. I frequently take trips with my bike involving multiple transit agencies and modes, and often travel off-peak with a bike. I'm passionate about transit and bikes, and I want it to be as easy as possible to combine the two modes. I think that BART embracing bikes and actively making it easier to bike to/from BART is incredibly important in moving the Bay Area toward sustainability and expanding BART's station catchment areas.

(6) Are you involved with any organizations or advisory boards related to public transit or bicycling?

- No, but my enthusiasm and fresh perspective are just what the BBATF needs
 Yes, please describe:

I serve on the Golden Gate Bridge, Highway and Transportation District's Bus Passenger Advisory Committee.

I'm also a member of SFMTA's Youth Transportation Advisory Board.

(7) Could you commit to attending most or all of the BBATF's 6 meetings each year?

Yes No

Not sure: _____

(8) How did you hear about the BBATF?

BART Twitter.

(9) What questions do you have about the role of the BBATF or being a BBATF member?

- Will the BBATF continue to be remote only?
- Does the BBATF also advise staff in addition to the board?

(10) Your information:

Cedar Makhijani

Name

San Francisco County

County of Residence

San Francisco County

County of Employment

Email and/or phone

Heath Maddox

From: Christopher White [REDACTED] >
Sent: Thursday, April 6, 2023 11:45 AM
To: Heath Maddox
Cc: Jon Spangler; Cedar Makhijani
Subject: Re: FW: BBATF Application

Hi Heath,
We're very happy to nominate Cedar to the BBATF! Thanks, Cedar, for being willing to volunteer your time and experience.

All the best,
Chris

--

Christopher White
Deputy Director
Phone or text: [REDACTED] [REDACTED]
Pronouns: he, him, his



[San Francisco Bicycle Coalition](#)
Promoting the Bicycle for Everyday Transportation
[1720 Market St.](#)
[San Francisco, CA 94102](#)



On Wed, Apr 5, 2023 at 11:49 AM Heath Maddox <hmaddox@bart.gov> wrote:

Hi Christopher,

We have another application from SF for the BBATF: Cedar Makhijani.

Would you be so kind to review his application and consider providing a nomination so the BBATF can act on this application at their June 2023 meeting?

BART Bicycle Advisory Task Force Membership Application

The BART Bicycle Advisory Task Force (BBATF) advises the BART Board on bicycle-related matters. The BBATF meets on the first Monday of even-numbered months from 6:00 to 8:00 PM in downtown Oakland at a BART-accessible location. Task force members are expected to attend all/most meetings. More information about the purpose of the task force can be found here: <http://www.bart.gov/about/bod/advisory/bicycle>

Please email application to:

Heath Maddox
BART Bike Program Manager
hmaddox@bart.gov
415-728-1352

(1) How frequently do use BART or other public transit?

- | | |
|---|---|
| <input type="checkbox"/> 5 days a week or more | <input type="checkbox"/> A couple times a month |
| <input checked="" type="checkbox"/> 1-4 days a week | <input type="checkbox"/> Once a month or less |

(2) How often do you use a bicycle to get to and from BART or other public transit?

- | | |
|--|---------------------------------------|
| <input type="checkbox"/> Always | <input type="checkbox"/> Occasionally |
| <input checked="" type="checkbox"/> Most of the time | <input type="checkbox"/> Never |

(3) How often do you use a bicycle to commute to work or for daily transportation?

- | | |
|--|---------------------------------------|
| <input type="checkbox"/> Always | <input type="checkbox"/> Occasionally |
| <input checked="" type="checkbox"/> Most of the time | <input type="checkbox"/> Never |

(4) What motivates you to want to serve on the BBATF?

Myself and my family are avid cyclists. We love the ability to be multi-modal by utilizing public transportation for trips that are further than biking with our child allows. My family consists of myself, my spouse, and our 16-month old daughter, as well as my parents who live in the unit below us. It's important to me to see safe streets for all types of cyclists and all types of cycles.

Majority of our rides consist of using an e-bike, both normal length and long. This has caused difficulty with public transportation for both busses and trains. I'd love to see improvement in this area and believe I can bring a strong voice to this issue.

(5) What perspectives, skills, or experiences you would bring to the BBATF?

I am an avid cyclist who has lived in multiple areas of the Bay, as well as eight years in Minneapolis, MN. I also travel frequently so I can bring a breadth of knowledge about how different areas utilize cycling with public transportation. I also have 8+ years of working professionally in the cycling industry, in both private and non-profit areas. I have a strong, natural ability to share my passion with others, which would be useful in a position like BBATF. I identify as a woman and have a young child, which would allow me to bring a needed perspective to the BBATF to make sure inclusive programming is being thought of. I also have 3+ years of project and program management experience.

(6) Are you involved with any organizations or advisory boards related to public transit or bicycling?

No, but my enthusiasm and fresh perspective are just what the BBATF needs

Yes, please describe:

I volunteer with Little Bellas and the National Interscholastic Cycling Association (NICA), both mountain bike programs for youth. I also am a Certified League Cycling Instructor with the League of American Cyclists. I am a member of the International Mountain Bike Association (IMBA), Santa Cruz Trail Stewardship, and San Francisco Bicycle Coalition.

(7) Could you commit to attending most or all of the BBATF's 6 meetings each year?

Yes No

Not sure: _____

(8) How did you hear about the BBATF?

I believe I saw someone post about it on Facebook or LinkedIn. I know many people in the Bay cycling community, so it was probably posted about at some point in my feed.

(9) What questions do you have about the role of the BBATF or being a BBATF member?

What skills or services are you in need of for a BBATF member?
Is there a maximum amount of time one can be a BBATF member?

(10) Your information:

Ashley Von Edge

Name

San Francisco

County of Residence

Currently unemployed

County of Employment

Email and/or phone

Heath Maddox

Subject: FW: BART Bicycle Advisory Task Force Membership Application - Ashley Von Edge

From: Christopher White [REDACTED] >
Sent: Wednesday, July 26, 2023 2:33 PM
To: Heath Maddox <hmaddox@bart.gov>
Cc: Ashley Von Edge <[REDACTED]>
Subject: Re: BART Bicycle Advisory Task Force Membership Application - Ashley Von Edge

Oh great! Then Ashley has our strong recommendation -- she's a rockstar!

--
Christopher White
Deputy Director
Phone or text: [REDACTED]
Pronouns: he, him, his

[San Francisco Bicycle Coalition](#)
Promoting the Bicycle for Everyday Transportation
[1720 Market St.](#)
[San Francisco, CA 94102](#)



On Wed, Jul 26, 2023 at 12:17 PM Heath Maddox <hmaddox@bart.gov> wrote:

Hi Christopher,

Ashley Von Edge has applied for membership on the BART Bicycle Advisory Committee (see attached), and we have an at-large vacancy.

Ashley has already attended a BBATF meeting, so all that's needed now for her application to be acted on is a nomination from SFBC.

I'm assembling the agenda packet now for the 8/7 meeting and need to have all the materials together by tomorrow morning. Hoping you can send something along today if possible!

Thanks,

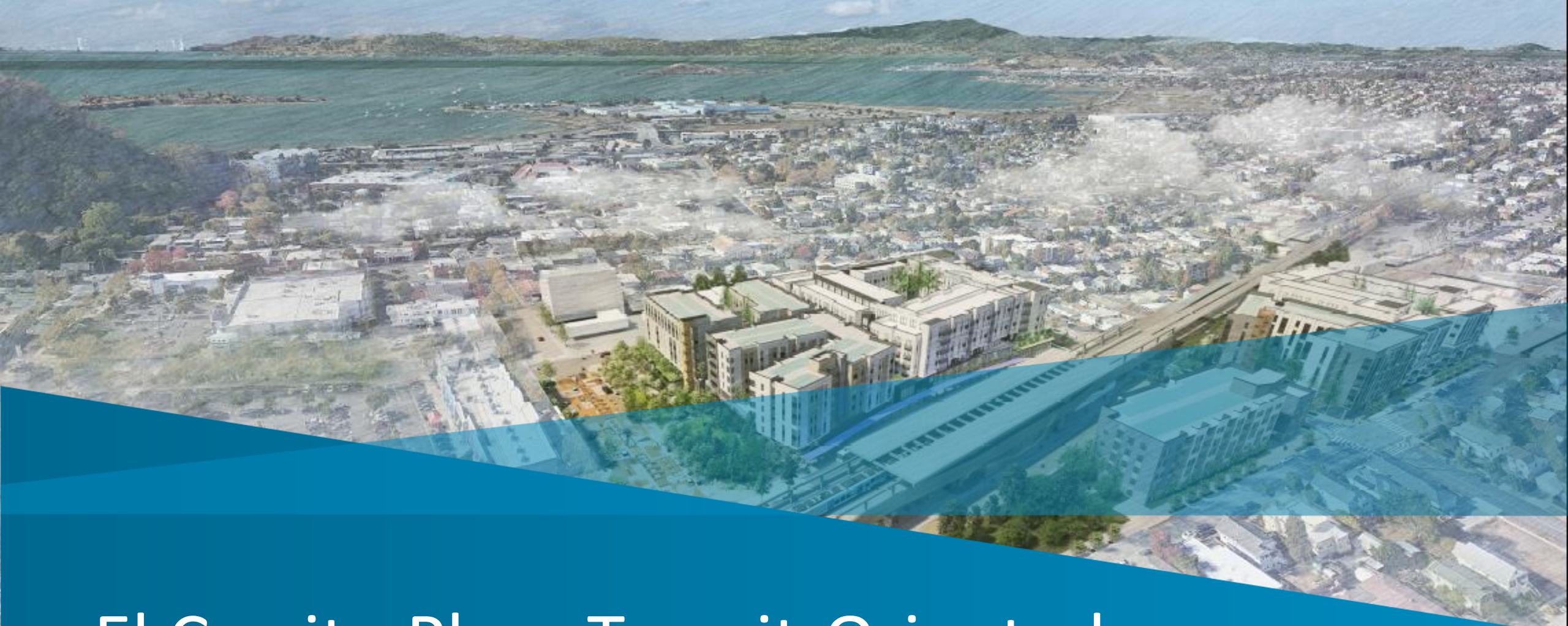

El Cerrito Plaza Transit-Oriented Development (TOD) Update

BBATF (8/07/2023)



Planning and Development Process

Development Timeline (subject to change)

2019-2023:

- BART Station Access Planning
 - Winter 2023: Caltrans Grant – Berkeley-El Cerrito Corridor Access Plan (BECCAP)
 - Spring 2023: Station Specific Access Plan
- Community Engagement
- Winter 2020: BART Selected Developer: Holliday Development/Related California

2021-2023

- Masterplan Design
- Funding awards for access improvements:
 - Summer 2022: Transit and Intercity Rail Capital Program (TIRCP): \$24.2M for Bike Station, Ohlone Greenway Improvements, Bus reconfiguration, Central Ave. Bikeway, BART parking garage, City on-street parking program
 - Fall 2022: Station allocation: \$1M

2023

- Spring 2023: City of El Cerrito approved Parcel A South (70-unit affordable) in Spring 2023
- Winter 2023: City of El Cerrito planning approvals for the remaining five buildings.

2024-2029

- Construction on first phase to start as early as Q4 2024 (Parcel A South)
- BART patron replacement parking built in Parcel B by end of 2027
- Final phase completed as early as Q3 2029 (Parcel A North)

El Cerrito Plaza TOD Overview

- 743 new homes (47% affordable) in 6 preliminary phases
 - A South: 70 affordable (Phase 1)
 - B: 259 market rate (Phase 2)
 - C-East: 84 affordable (Phase 3)
 - C-West: 79 affordable (Phase 4)
 - D: 118 high-AMI affordable (Phase 5)
 - A North: 133 market rate (Phase 6)
- New public open space
- Potential for new public library (C-West)
- Café/retail space (C-East)
- 1,100 TOD bike parking spaces
- Bike station: 215-275 spaces (subject to change)
- 100-150 BART rider parking spaces
- Around 260 TOD resident parking spaces

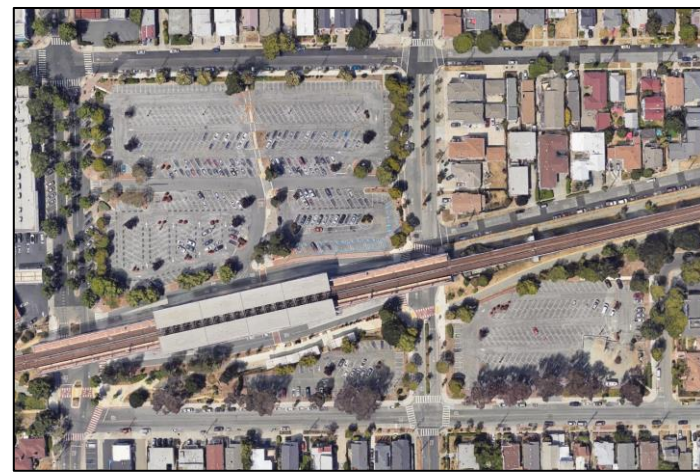



BECCAP – Corridorwide Recommendations

Strategy	Extents	Lead Agency
Reinstate Transbay Bus Service and Increase Service Frequency	Gilman St, Hopkins St, Monterey Ave. from Marin Ave to I-80, and Arlington Ave	AC Transit
Carlson / Pierce New Transbay Service	Richmond Annex to I-80/Buchanan St on Carlson Blvd and Pierce St	AC Transit
Arlington Late Evening Bus Service	Arlington Ave from El Cerrito Del Norte and the Berkeley Hills to Downtown Berkeley BART Station	AC Transit
Clipper Cash Promotion	Study Area	MTC, Alameda CTC, CCTA, WCCTAC
Infrastructure Improvements for Bus Reliability	High ridership routes to stations within 1.5 miles	Cities of Berkeley, El Cerrito, and Albany
Outreach to provide Information on strategies	Study Area	BART
Electric Bike Lending Library	Attended bike station	BART, Cities, Bike Hub
Micromobility: Regional Coordination	El Cerrito, Albany, Richmond, Kensington (unincorporated Contra Costa County)	Cities of Albany, El Cerrito, and Richmond
Context-sensitive Lighting Improvements	On main pedestrian corridors within a 15 min walk (0.75 miles) from the BART stations	BART, Cities of Berkeley and El Cerrito

Corridor Access Strategies

Mapped

- C-03: Arlington late evening bus service*
- C-04: New AC Transit Transbay line on Carlson and Pierce St*
- C-05: Reinstate Transbay bus service and increase service frequency*
- C-15: Construct bicycle boulevard
- C-16: Construct bicycle boulevard
- C-17: Addison Street Bicycle Boulevard Project
- C-18: PivotPoint Commuter Hub at I-80/Buchanan
- C-19: Alameda County San Pablo Ave Corridor Project

Unmapped**

- C-01: Bus stop infrastructure improvements
- C-02: On-street improvements for bus reliability
- C-06: Education on existing and future station access options
- C-07: Shared parking education
- C-08: Encourage and/or facilitate carpooling through BART parking app, 511, and other apps
- C-09: Provide financial incentives for shared and active mode use
- C-10: Electric bike lending library
- C-11: Expand bike infrastructure and parking options at BART stations
- C-12: Implement and regionally coordinate micromobility
- C-13: Context-sensitive lighting near stations and bus stops
- C-14: Clipper Cash promotion
- C-20: Berkeley Street Light Comprehensive Plan
- C-21: Transit Fare Coordination and Integration

*The routes shown are not final. Additional outreach and coordination will be done on these routes during AC Transit's Network Redesign Process.
 **C22-C33 are a set of private mobility apps/services that are unmapped.

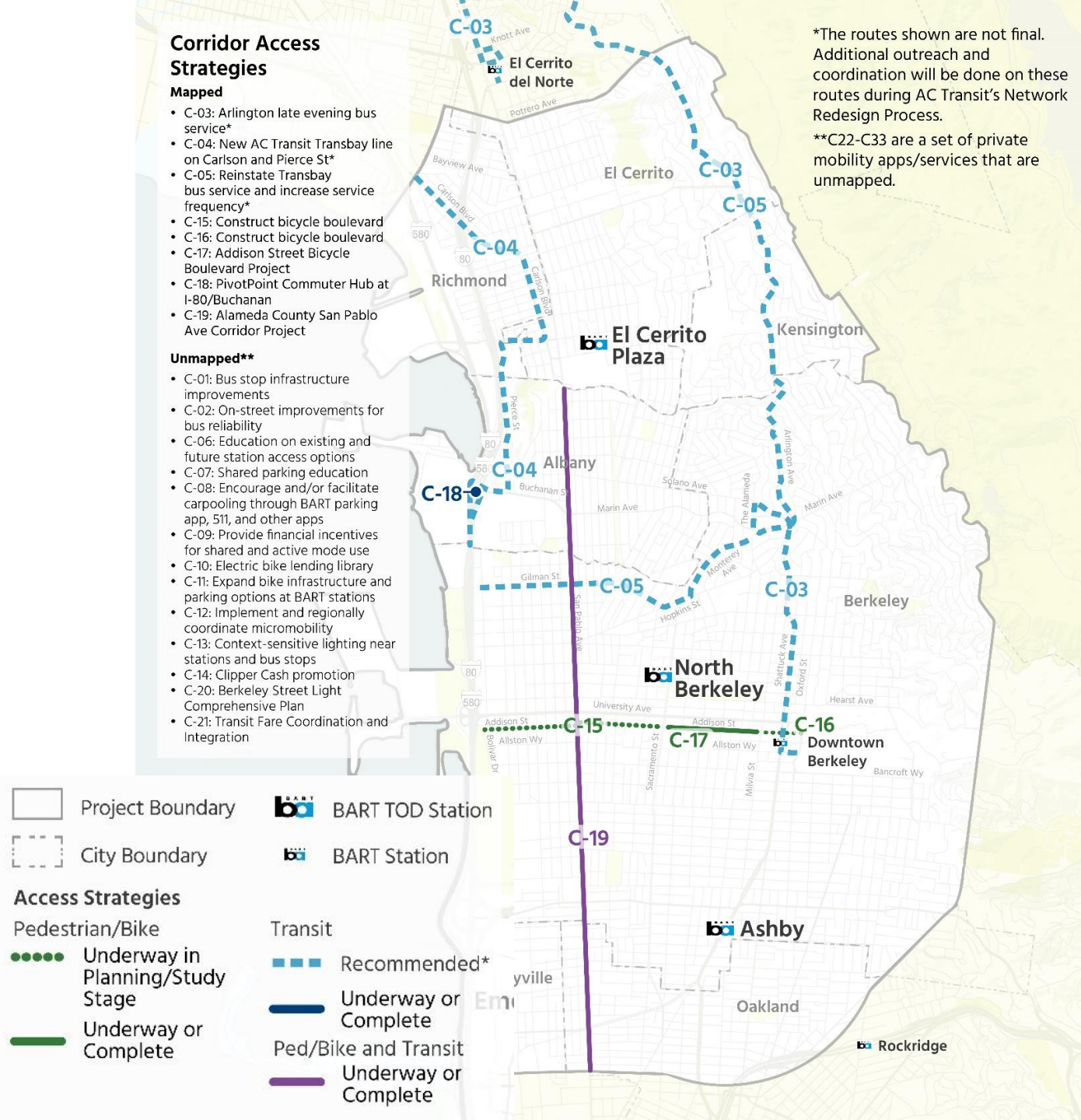

BECCAP – Station Specific Recommendations

Strategy	Extents	Lead Agency
Ohlone Greenway Improvements	Ohlone Greenway from El Cerrito del Norte to the border between Albany / Berkeley	City of El Cerrito and Albany
Fairmount Biking and Walking Improvements	Fairmount Ave from Carlson Blvd to Colusa Ave	City of El Cerrito
East Side Bicycle Boulevard Implementation	Norwell St, Lincoln St, Albemarle St, Behrens St from Moeser Ln to the end of Behrens St	City of El Cerrito
Carlson Biking and Walking Improvements	Carlson Blvd from Columbia Ave to San Pablo Ave / El Cerrito Plaza	City of El Cerrito
Pierce / Cerrito Creek Trail Biking and Walking Improvements	Central Ave to Cerrito Creek Trail along Pierce St, Pierce St to Carlson Blvd	City of El Cerrito
Lincoln Bicycle Boulevard	Lincoln Ave from San Pablo Ave to Ashbury Ave	City of El Cerrito
Frequent Bus Service on Carlson Blvd Line 71	Carlson Blvd from Northwest Study Area boundary to El Cerrito Plaza	AC Transit
Restore Bus Service on Pierce St through University Village	Pierce St from Marin Ave / San Pablo Ave to Buchanan St / Pierce St to El Cerrito Plaza	AC Transit
Richmond St Bus Service	North of El Cerrito Plaza	AC Transit
On-street parking program	¼ mile around BART station	City of El Cerrito

El Cerrito Plaza Access Strategies

- Mapped**
- E-01: More frequent line 71 bus service*
 - E-02: Restore bus service on Pierce Street and through University Village, connecting to El Cerrito Plaza station*
 - E-03: Richmond St Bus Service*
 - E-04, E-06, E-08, E-09, E-10, E-11, E-12: Biking and walking improvements
 - E-05: Ohlone Greenway Improvements
 - E-07: Implement the East Side Bicycle Boulevard
 - E-13: Implement Richmond Annex Bikeways
 - E-16: On-site parking garage
 - E-17: Contra Costa County San Pablo Corridor Project
 - E-18: San Pablo Ave Midtown Complete Streets
 - E-19: El Cerrito Plaza BART Access Plan (at station)
 - E-20: Carlson Blvd and San Diego Street Pedestrian Crossing Improvements
 - E-21: 2021 Sidewalk Repair Project on San Pablo Avenue
- Unmapped**
- E-14: Expand docked bike share system
 - E-15: On-street parking management near station
 - E-22: El Cerrito Lighting Study

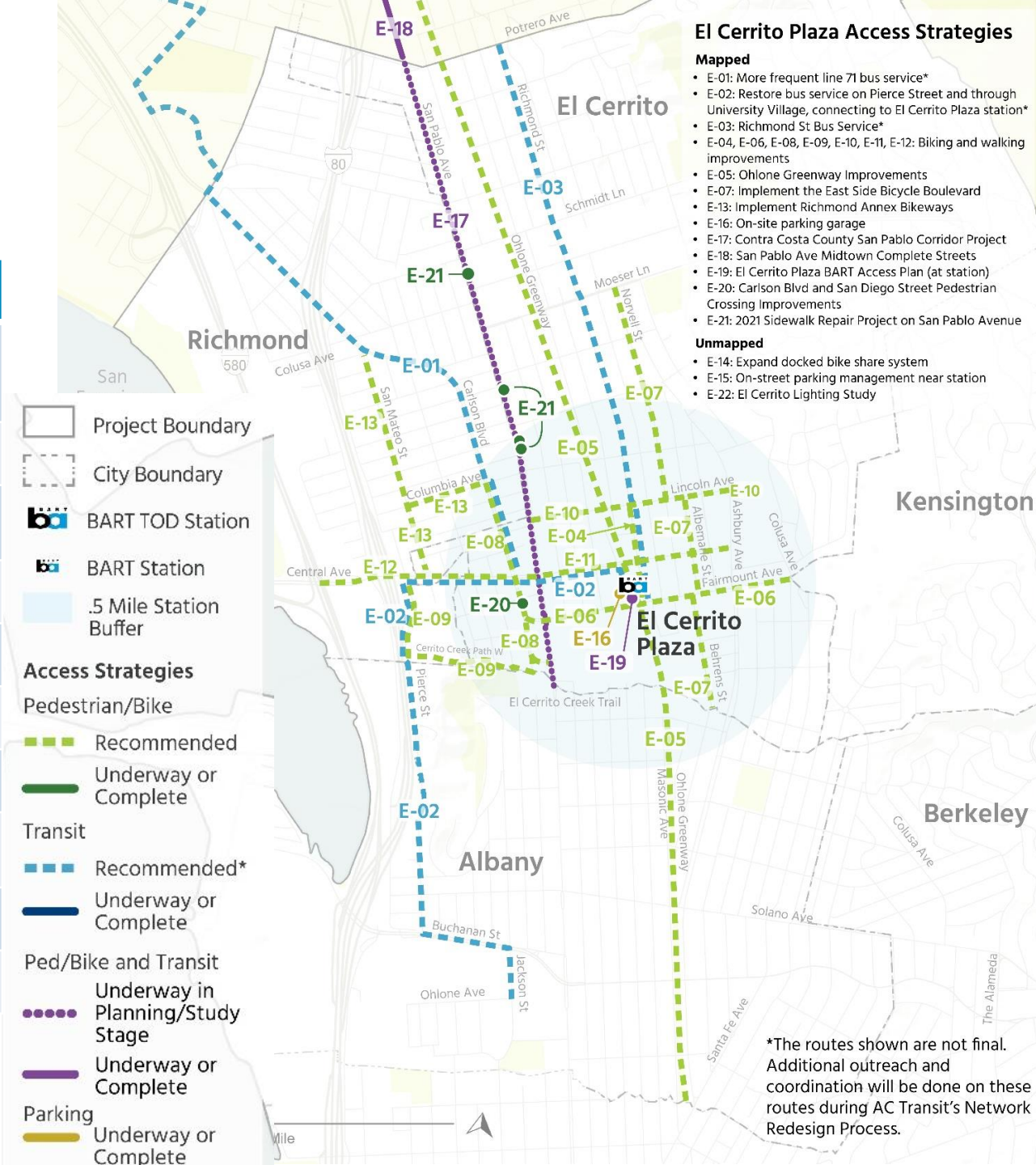

*The routes shown are not final. Additional outreach and coordination will be done on these routes during AC Transit's Network Redesign Process.

Access Plan Curb Use

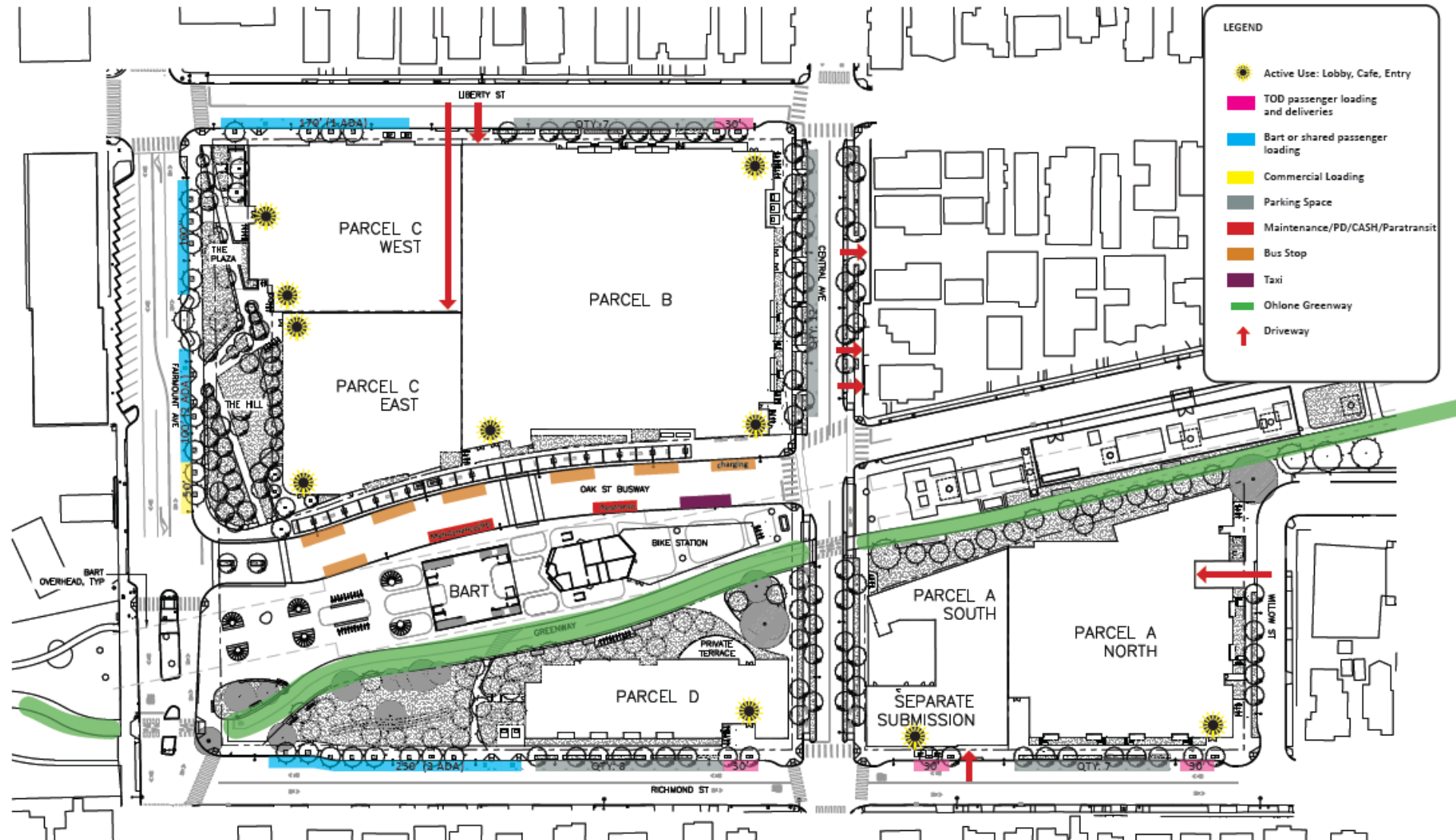

Access Plan: Pedestrian Access

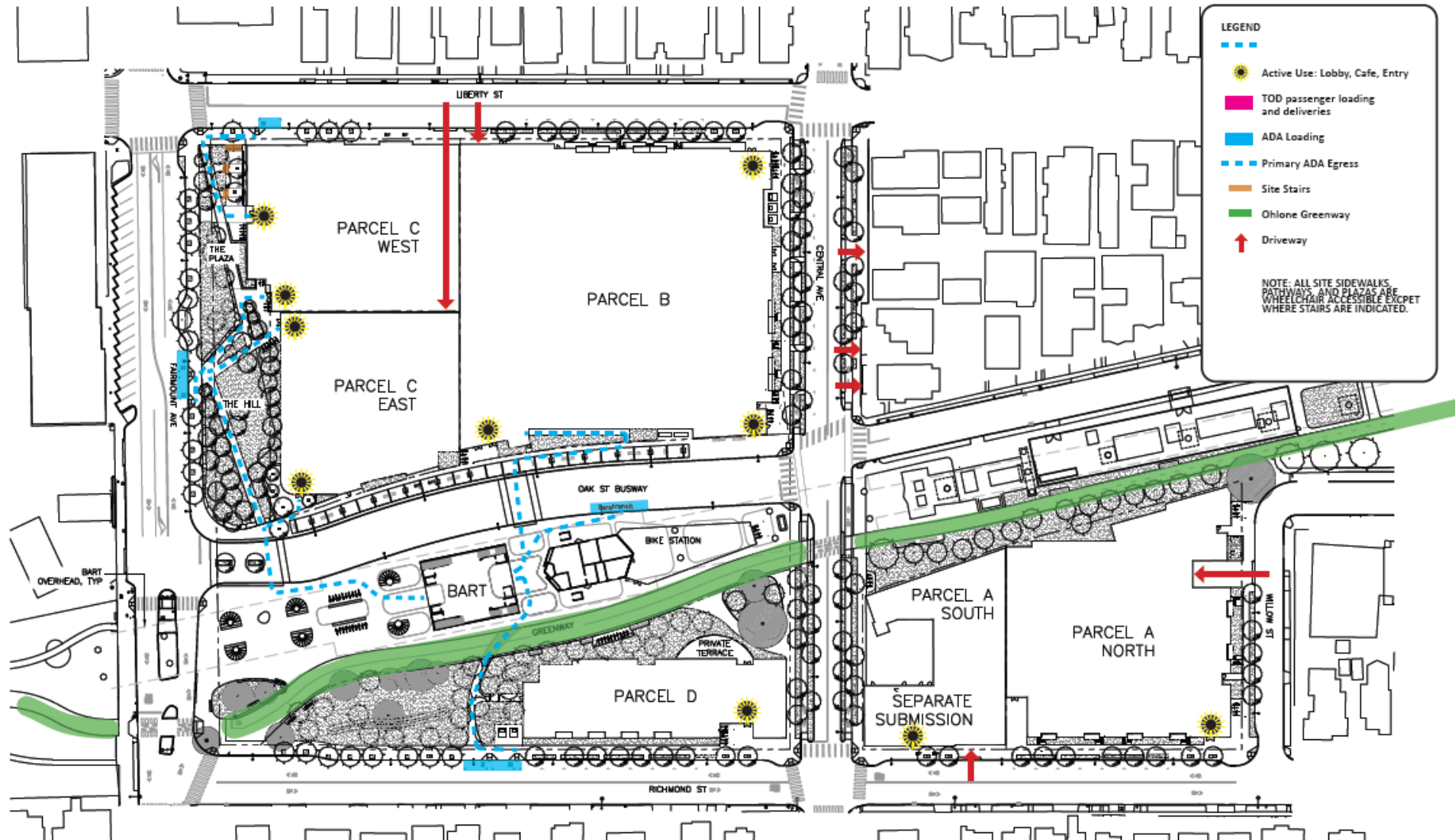

Access Plan: Bike Access

Longer term: City to evaluate the feasibility of Class II bike lanes or Class IV separated bikeways on Fairmount

City is conducting a study to determine ultimate future configuration of East-West Bikeway on Central Ave.

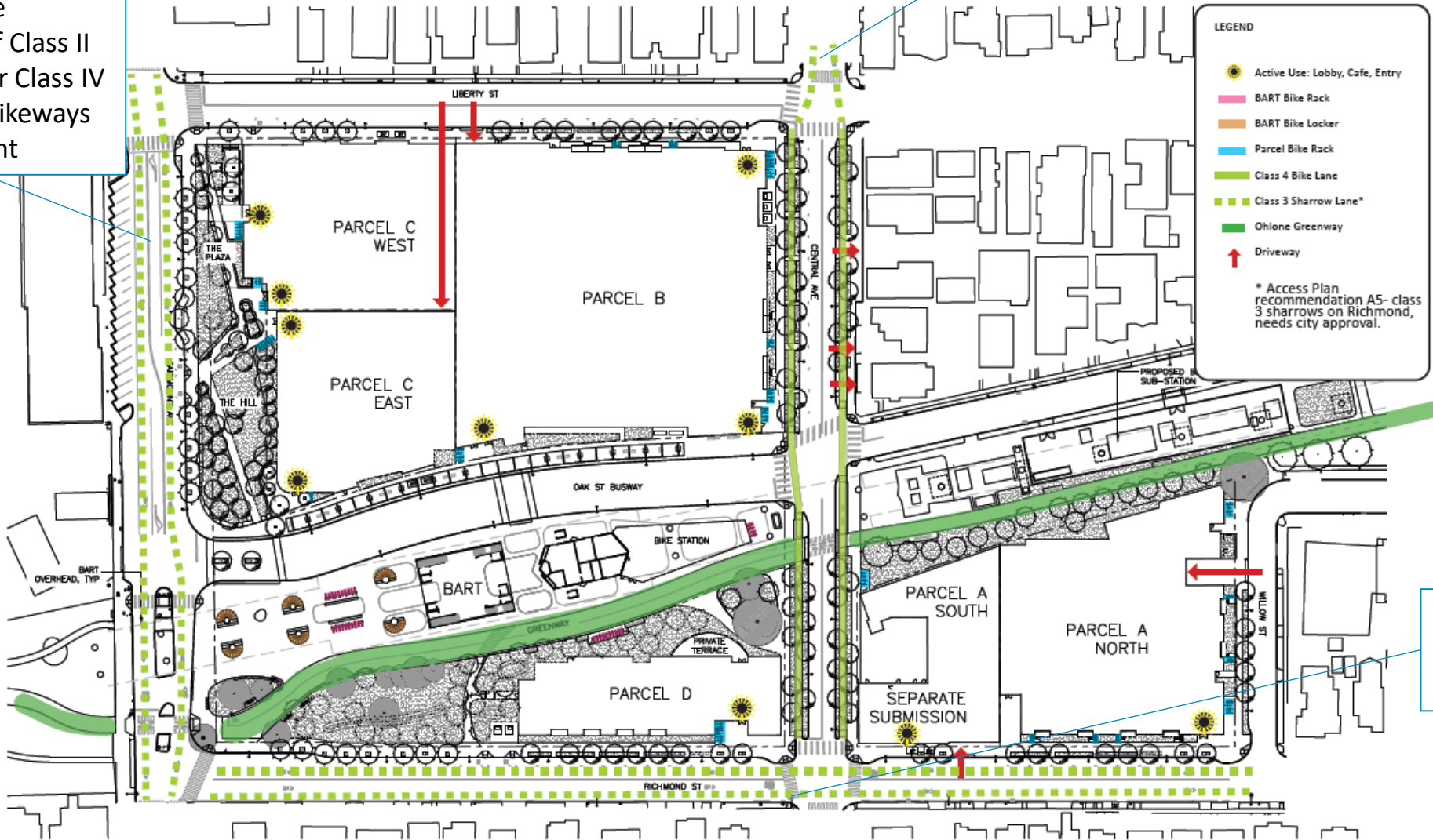

Class III sharrows on Richmond St. need City approval

Thank you!

For more information on the Berkeley-El Cerrito Corridor Access Plan, go to:

www.bart.gov/beccap

To learn more about the El Cerrito Plaza TOD:

<https://elcerritotod.squarespace.com/>



Safe Routes to BART (SR2B) Grant Program Cycle 3 Update

BBATF (8/07/2023)



BART Station Access Policy Goals



A. Safer, Healthier, Greener

Advance the region's safety, public health, and greenhouse gas (GHG) and pollution-reduction goals.



B. More Riders

Invest in station access to connect more riders cost effectively, especially where and when BART has available capacity.



C. More Productive and Efficient

Manage access investments, programs, and current assets to achieve goals at the least cost.



D. Better Experience

Be a better neighbor, and strive for an excellent customer experience, including on the first and last mile of the trip to and from BART stations.



E. Equitable Services

Invest in access choices for all riders, particularly those with the fewest choices.



F. Innovation and Partnerships

Be an innovation leader, and establish durable partnerships with municipalities, access providers, and technology companies.

BART Board adopted June 9, 2016

Intended Allocation by Mode (\$135 M)

- Access program is 4% of \$3.5 B Measure RR funds
- Invest to meet:
 - Station Access Policy Goals
 - Mode share targets

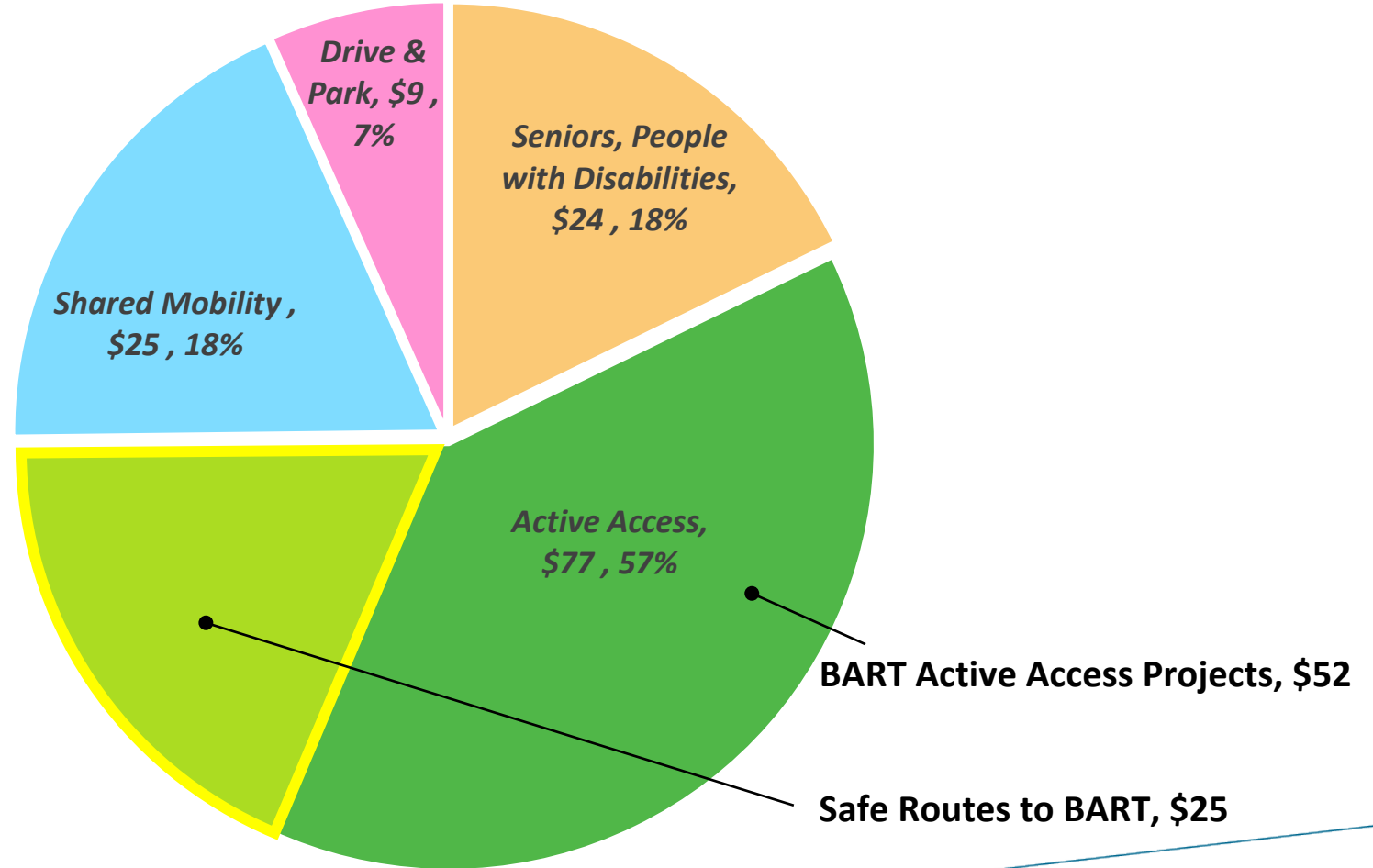

Safe Routes to BART Program

- Overview
 - Fund active access capital projects on city and county streets that support BART's Station Access Policy
- Program Goals
 - **Project readiness** to quickly deliver projects that help riders access BART
 - **Leverage** funding from other sources
 - **Connectivity and mode shift** that transitions riders away from driving in favor of walking and biking
 - **Customer experience** enhancements that enrich rider comfort, personal safety, and sense of place
 - **Equitable** access for disadvantaged communities
 - **Complete communities** that promote transit-oriented development
 - **Partnership** with local agencies to create more sustainable communities

SR2B Cycles

Call for projects

- Cycle 1: May 2020
- Cycle 2: January 2023

Awards: \$500K to \$1.5M

Added requirement in Cycle 2

- Proof of authority over right-of-way to implement project elements

Cycle	Project	Agency
1	Iron Horse Trail Bridge	Dublin
1	5th Street Improvement	SFMTA
1	Ped/Bike Connectivity	Pittsburg
1	Walnut/Liberty Protected Intersection	Fremont
2	Complete Streets Improvement	El Cerrito
2	Walnut Ave Bikeway Phase II	Fremont



SR2B Cycle 3 Basics

- Funding
 - Cycle 3/Final Cycle: ~ **\$16M**
 - Funding awards between **\$0.5M and \$3M**
 - Funds must be used for **construction or construction management**
- Proposed Project
 - 1 submission/applicant/cycle
 - Co-sponsoring with one or more agencies allowed
 - Project types
 - Walking and/or biking improvements per BART station
 - One intervention that covers two or more stations (lighting is an example)
- Successful applicant's responsibilities
 - Permitting, environmental, construction, operations and maintenance

Eligibility

- Applicants must:
 - Be public agencies in Alameda, Contra Costa and San Francisco counties
 - Have a **minimum match** for the Proposed Project of **30%**, not including staff time
 - Have proof of authority over elements of Proposed Project requesting SR2B funds
 - Demonstrate support within their agency and from the community
 - Demonstrate support from a Citizen Committee or Advocacy Organization
 - Have a funding plan for the Proposed Project
- The Proposed Project must:
 - Be located fully within Alameda, Contra Costa and San Francisco counties
 - Help meet BART adopted goals and targets
 - Have design review construction documents completed to **at least 35%**
 - Have a delivery plan with schedule and major milestones
 - Up to 3.5 years of award date
 - Up to 1.5 years from construction NTP
- Proposed Projects may be part of a larger project

Eligible Improvements and Examples

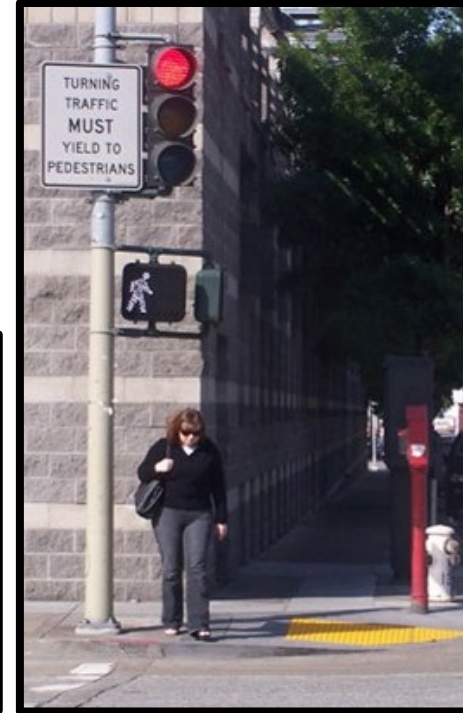

Eligible Costs

- Eligible costs
 - Construction only
 - May include construction management
 - Directly related material, equipment rental
 - Fixtures (permanently affixed)
 - Labor charges directly related to construction
 - Permit fees
- Ineligible costs
 - Work conducted prior to funding agreement
 - Feasibility and planning studies
 - Design
 - Operations & maintenance
 - Costs not directly related to construction
 - Equipment that can be moved (computers, chairs)
 - Grant administration

Application Evaluation Criteria

Selection Criteria	Station Access Policy Goals	Weight
A. Project Readiness	C. More Productive & Efficient	20%
B. Leveraged Funding	C. More Productive & Efficient	10%
C. Connectivity and Mode Shift	A. Safer, Healthier, Greener B. More riders D. Better Experience	20%
D. Customer Experience, Safety and Security	D. Better Experience	15%
E. Equitable Access	E. Equitable Services	15%
F. Complete Communities	D. Better Experience B. More riders	10%
G. Partnerships	F. Innovation & Partnerships	10%

SR2B Cycle 3 Schedule (Tentative)

- Inquiry Forms: Due August 10
- Call for Projects: Late September 2023
- Pre-Application Webinar/Q&A period: October 2023
- Application Deadline: November 2023
- Award notice: Winter 2023/24
- Funding agreements: Winter/Spring 2024

Visit www.bart.gov/sr2b for more info
Email: sr2b@bart.gov



VTA response to BBATF Questions from 6/5/23 BART to Silicon Valley Phase II Presentation

Adriano Rothschild

External Affairs Team - Stakeholder Coordinator

VTA's BART Silicon Valley Program

Santa Clara Valley Transportation Authority

1. Why do the Downtown and Little Portugal stations have the same number of bike parking spots when DTSJ has 4x riders?
 - a. In short, bike parking is based on AM boardings, not overall daily ridership. The 28th Street/Little Portugal and DTSJ Stations have similar numbers of expected AM boardings and thus have similar bike parking needs.
 - i. The Downtown San Jose Station has much higher total ridership than 28th Street/Little Portugal but has what is sometimes referred to as a "tidal" ridership pattern. For DTSJ, this means that the morning peak sees a majority of riders exiting BART, as trips in DTSJ will largely be driven by employment and schools, resulting in relatively low number of AM passengers arriving at the station. Additionally, a large portion of our DTSJ ridership is anticipated to access the station via transit (bus or LRT). Therefore, many of the passengers arriving at the station would in fact be arriving via transit.
 - ii. The 28th Street/Little Portugal Station, on the other hand, has a more balanced ridership pattern - one that could even be viewed as the opposite of DTSJ's, as ridership at this station is largely being driven by housing (i.e., trips will start here) rather than employment uses. Therefore, the 28th Street/Little Portugal Station will have much higher percent of total passengers that would arrive at the station in the morning.
2. Please explain VTA's methodology for projecting bike access numbers and calculating bike parking demand.
 - a. VTA's methodology assumes 9% of forecasted AM total boardings by 2040 require bicycle parking in accordance with APBP Bicycle Parking Guidelines Target Bicycle Parking Mode Share. This results in a bicycle parking demand of 340 at DTSJ and 320 at 28th Street/Little Portugal.
 - b. Of 2040 bicycle parking demand, 80% are to be provided on opening day. This equates to 270 spaces at DTSJ and 250 at 28th Street/Little Portugal.
 - c. Bicycle parking will be provided in a 75%/25% split between secure lockers/bike station spaces and bike racks is assumed in accordance with both BART and VTA guidance.
3. Are there existing BART stations that might have similar current ridership to the projected ridership numbers for DTSJ, Diridon, or Little Portugal/28th? How much current/planned bike parking do these existing BART stations have?
 - a. While VTA considered and looked at parking supply other BART stations with similar ridership and station classifications, the land use context and bicycle infrastructure surrounding the BSVII stations differs from many of the existing stations. Therefore, the methodology described above was used for determining bike parking supply.
4. Double-sided elevators need to be ubiquitous since station designs are relying on elevators for bike access to overcome the challenges of vertical circulation with such deep platforms. Are elevators double-sided wherever possible?
 - a. Yes, wherever possible. Currently we anticipate all platform elevators at the three underground stations to be double-sided. I will note that I heard from BBATF members a desire for these elevators to open both doors at both levels, but the exact opposite comment was provided to us by the BART. Currently our plans are to have only one door open at each level - though this is a minor detail that can be addressed as design advances.
5. What happens if elevators are out of order? Are all stairways wide enough to accommodate bikes? Have you considered bike escalators?

- a. BART does not allow bikes on escalators for safety reasons. VTA does not have any authority to change that. Multiple redundant elevators are being provided at each station, so elevators would be available for bicyclists. We are fitting stairways as wide as we can accommodate, but in coordination with BART the elevators have been identified as the primary bike access route.
 - b. VTA is not planning to include any bike escalators. To our knowledge BART does not have these at any other station (Heath, please correct me if I'm wrong), we have not heard any request from BART to include them.
6. At what point will VTA know when a northside entrance to Diridon and south entrance to DTSJ will be added? What would the cost of these entrances be?
- a. These are not part of our project, do not have identified funding sources, and have not been environmentally cleared. VTA is not precluding the possibility of these future connections, but they are not part of our current Project. At this time, there are no concrete plans for these future entrances to be realized.
7. Please confirm sizes of elevators, and whether they will all fit cargo bikes (provide min/typical dimension)
- a. Downtown San Jose and Diridon Primary Station Entrances
 1. Elevators (entry to concourse level) are 5'5" (65") deep x 7'8" (92") wide, with a diagonal of 112"
 2. Platform elevators (All doors are side opening 42" wide and the dimensions shown below do not reflect the small amount of extra space at the door recess. Subject to change)
 1. Diridon: 5'-6"w x 7'-8"d, 42" front and rear doors
 2. Downtown: 5'-6"w x 7'-8"d, front and rear doors
 - b. Downtown San Jose Secondary Entrance
 1. Elevators (entry to concourse level) are 5'5" (65") deep x 4'10" (58") wide, with a diagonal of (87") - Subject to change. Please note that the primary access route for bicyclists will be via the primary station entrance, as this secondary entrance is too space-constrained to accommodate larger elevators.
 - c. 28th Street/Little Portugal Station
 1. Elevators (entry to concourse and platform) are 8'8.5" (104.5") deep x 4'10" (58") wide, with a diagonal of 119.5" (the largest elevators in the BART system are 120" in diameter). Subject to change.
 - d. Santa Clara Station
 1. Santa Clara Station will be an at-grade station, and the primary path of travel for bicyclists will be the use of stairs, which are being designed with bike channels. Elevators at this station are being prioritized for mobility-impaired riders.
 2. Elevators are 6'-6"w x 6'-5.5"d. Subject to change.
 - e. In summary, it is likely that not all cargo bikes would be accommodated within our elevators and therefore passengers with these bikes would not be able to bring their bikes onto the BART train. BART's current approach for addressing the ever-increasing size of these cargo bikes has been to communicate to riders to double-check that their bikes would fit in the elevators they are using. I believe elevators at the stations on this extension are larger than the typical BART elevators, so it is likely that riders' ability to bring their bikes on the train is more likely limited by existing infrastructure. (Not sure how many people use the bike channels for their heavy cargo bikes). [BART_ElevatorDimensions_051722.pdf](#)

Thank you again for the opportunity to present to the BBATF, and we look forward to being able to provide more updates in the future.

Agenda Item 9: BART Bike Program Updates: Heath Maddox, BART Customer Access.
(For Information)



Monthly Volumes at BART Bike Stations & BART Ridership Jan 2019-June 2023

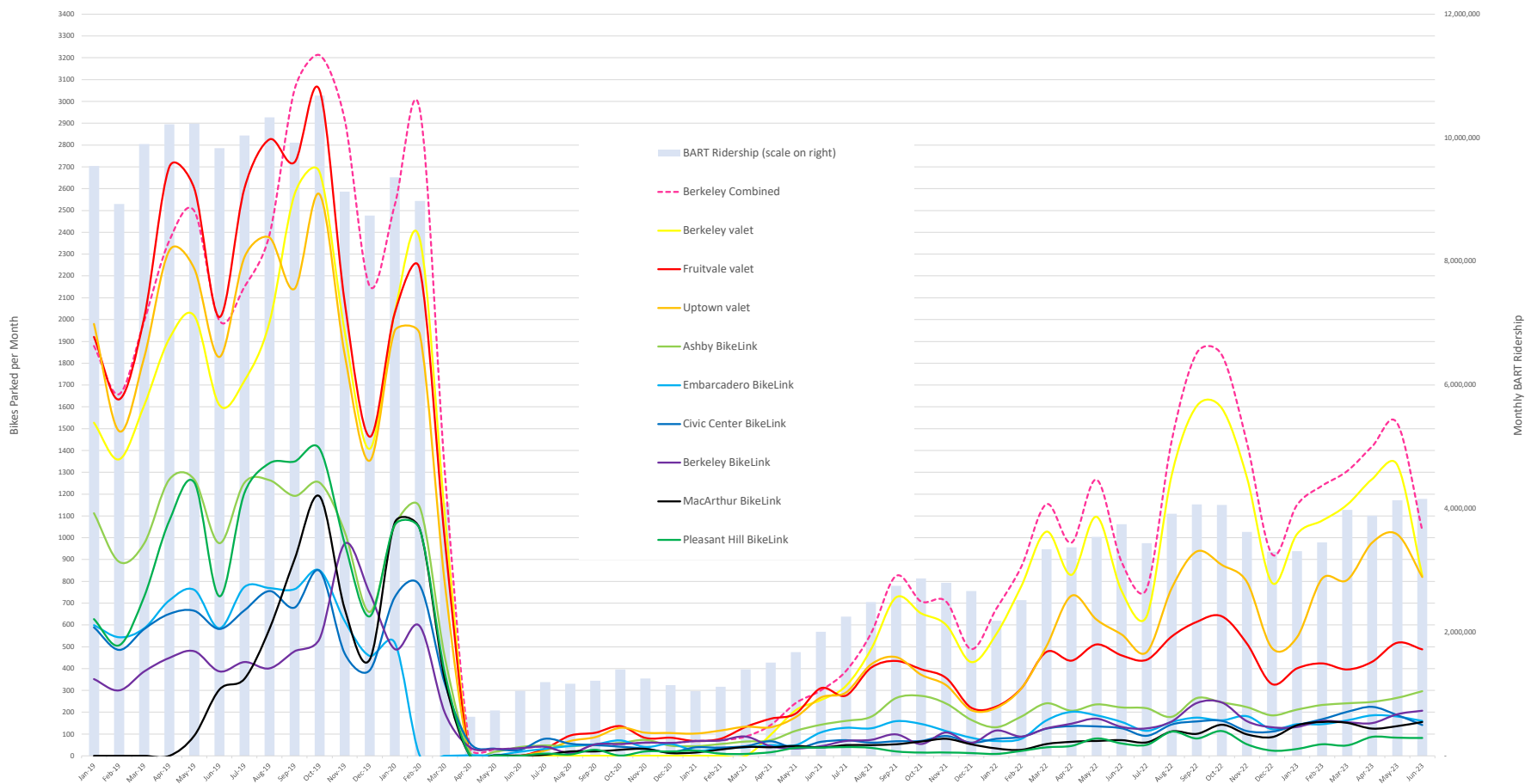



Monthly Volumes at BART Bikeep Smart Racks & BART Ridership Jan 2019-June 2023

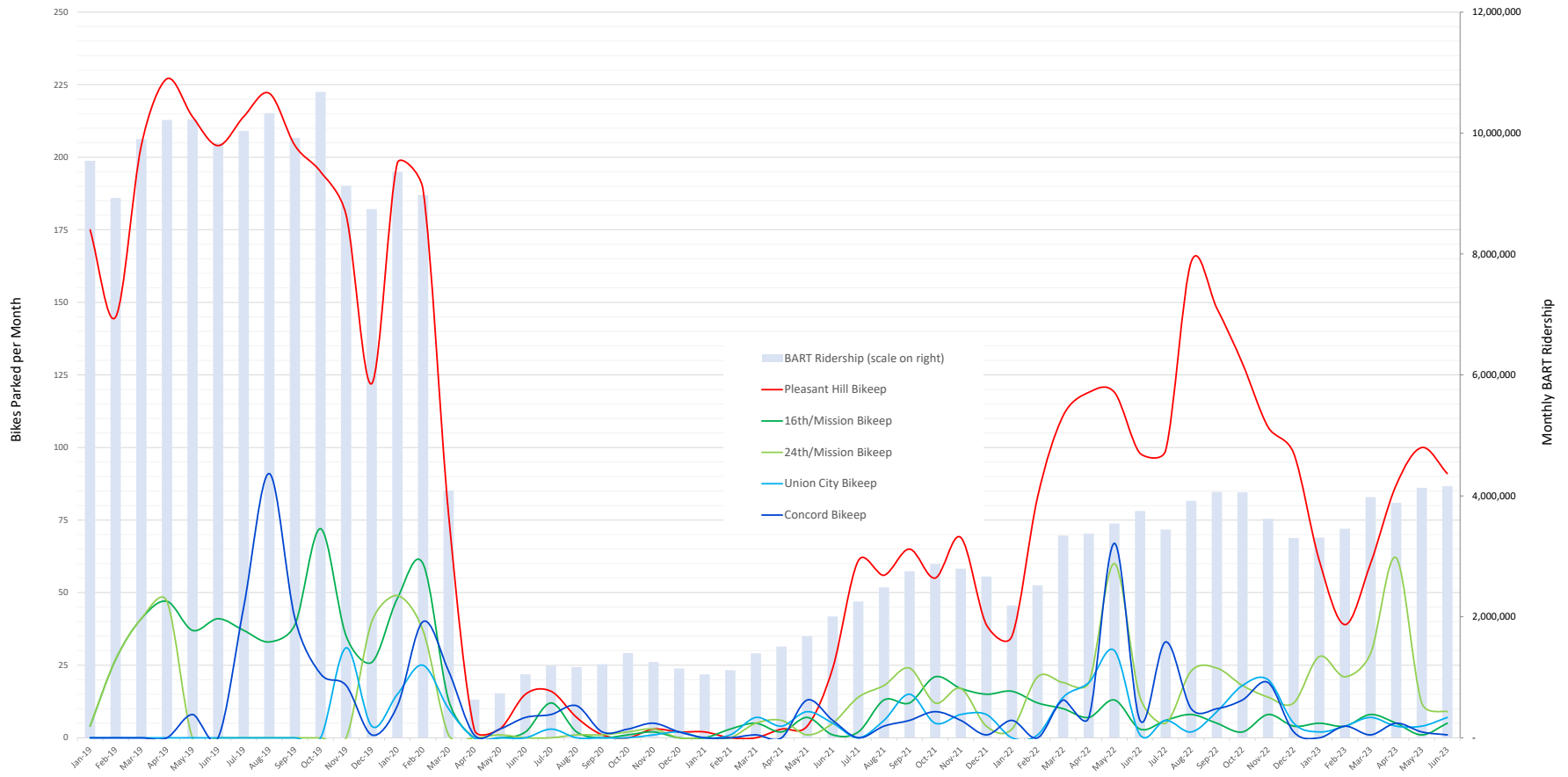



Monthly Rentals at all BikeLink Bike Lockers and BART Bike Stations vs. BART Ridership Jan 2019-June 2023

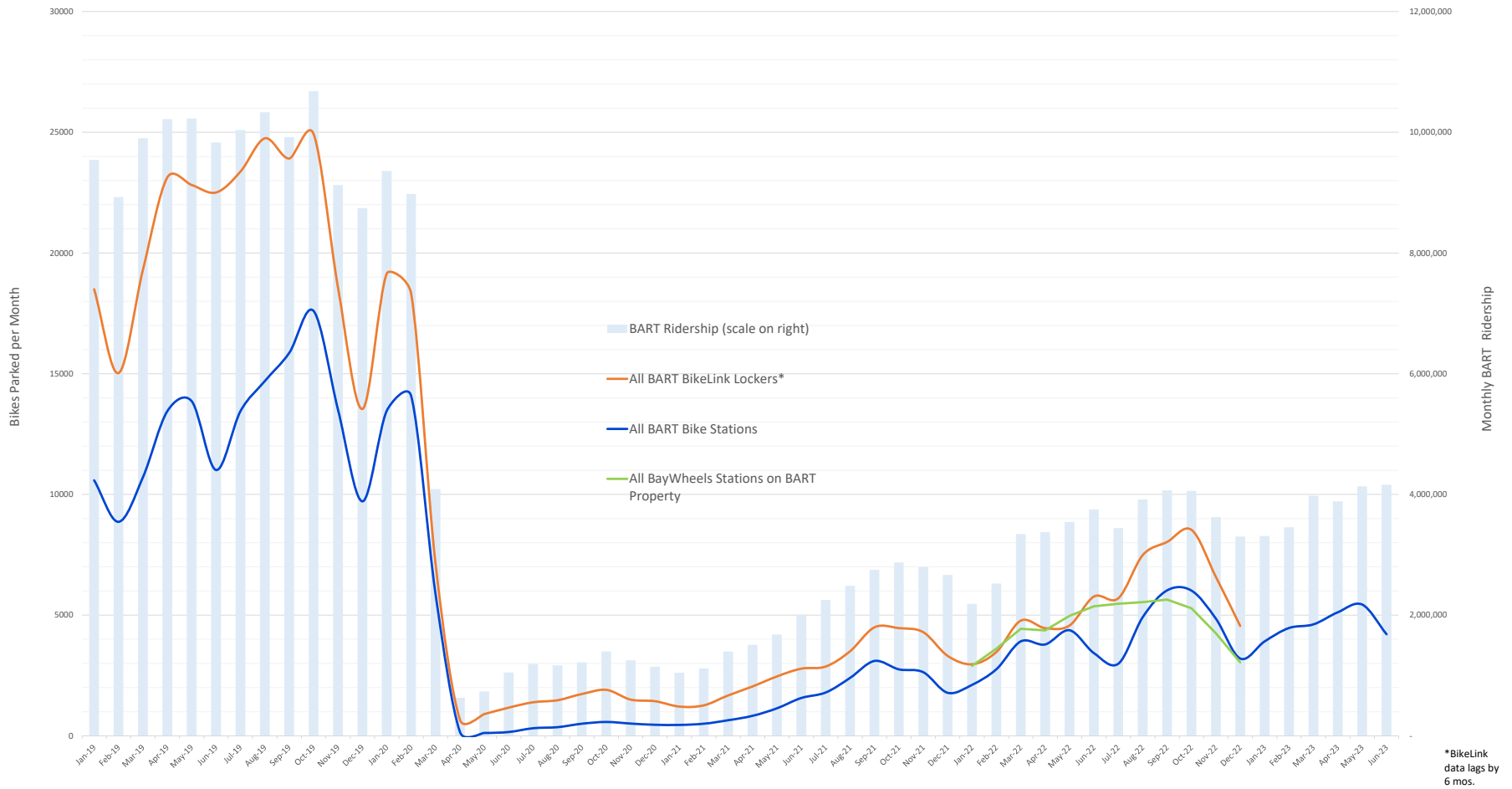

*BikeLink data lags by 6 mos.

Existing

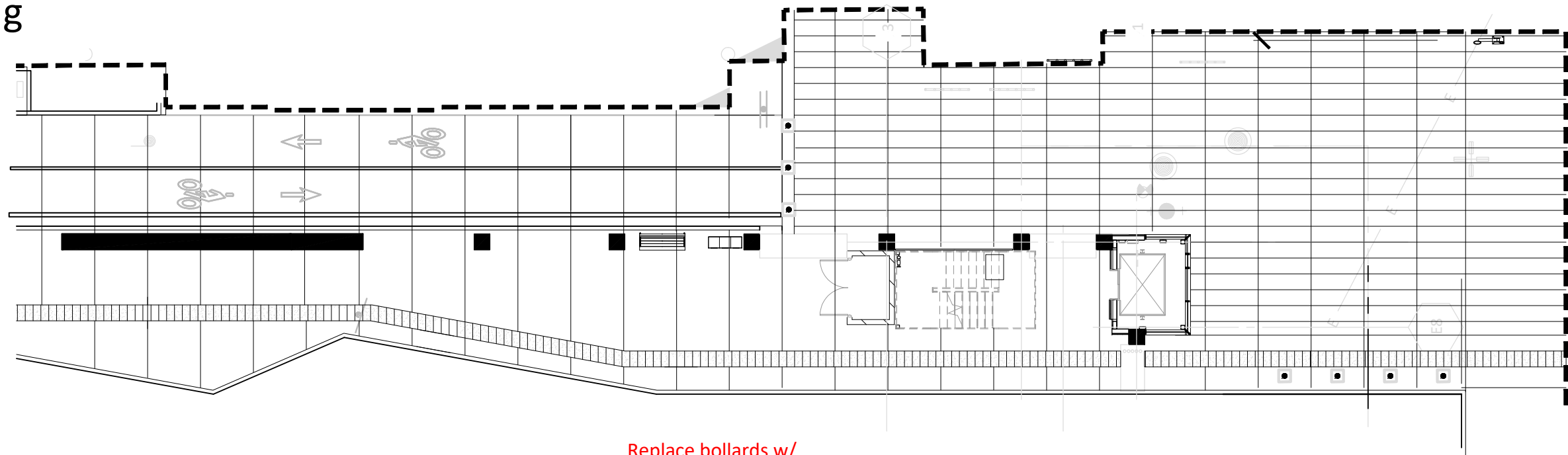

Proposed

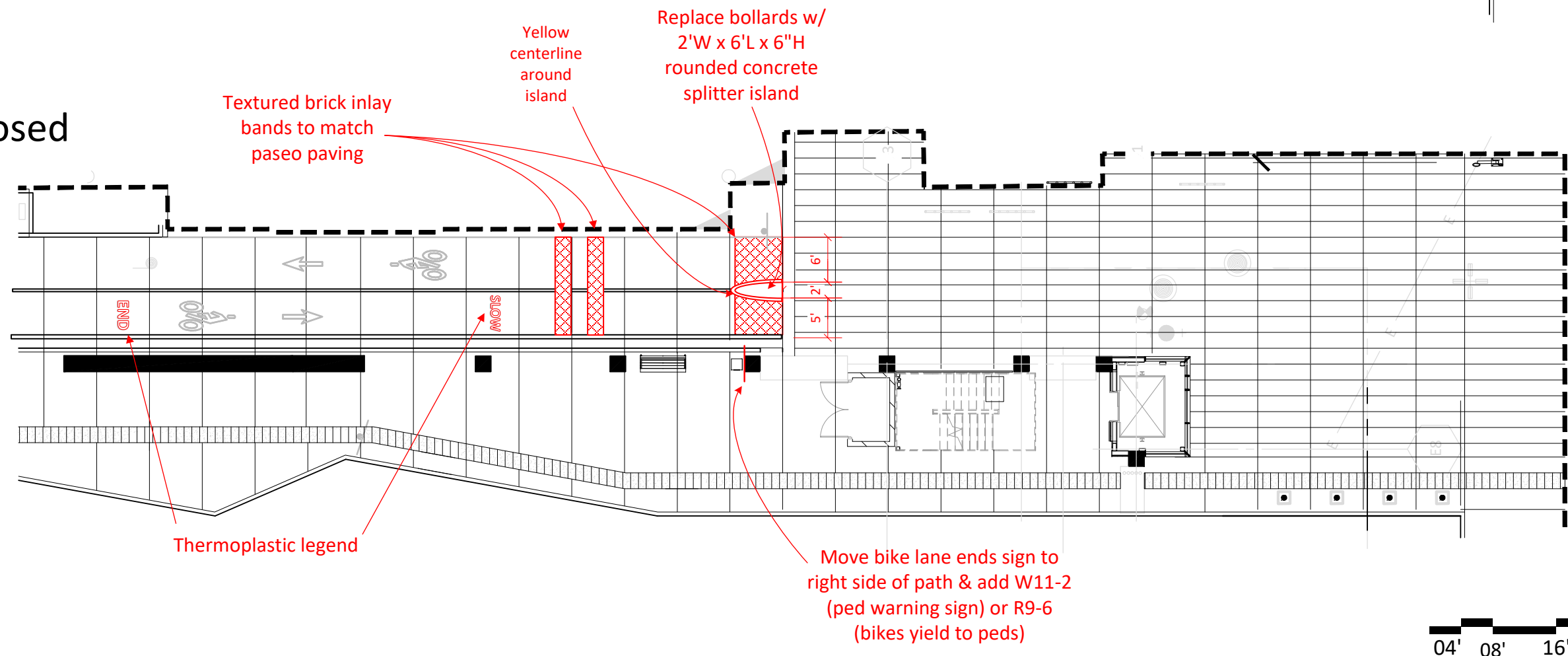

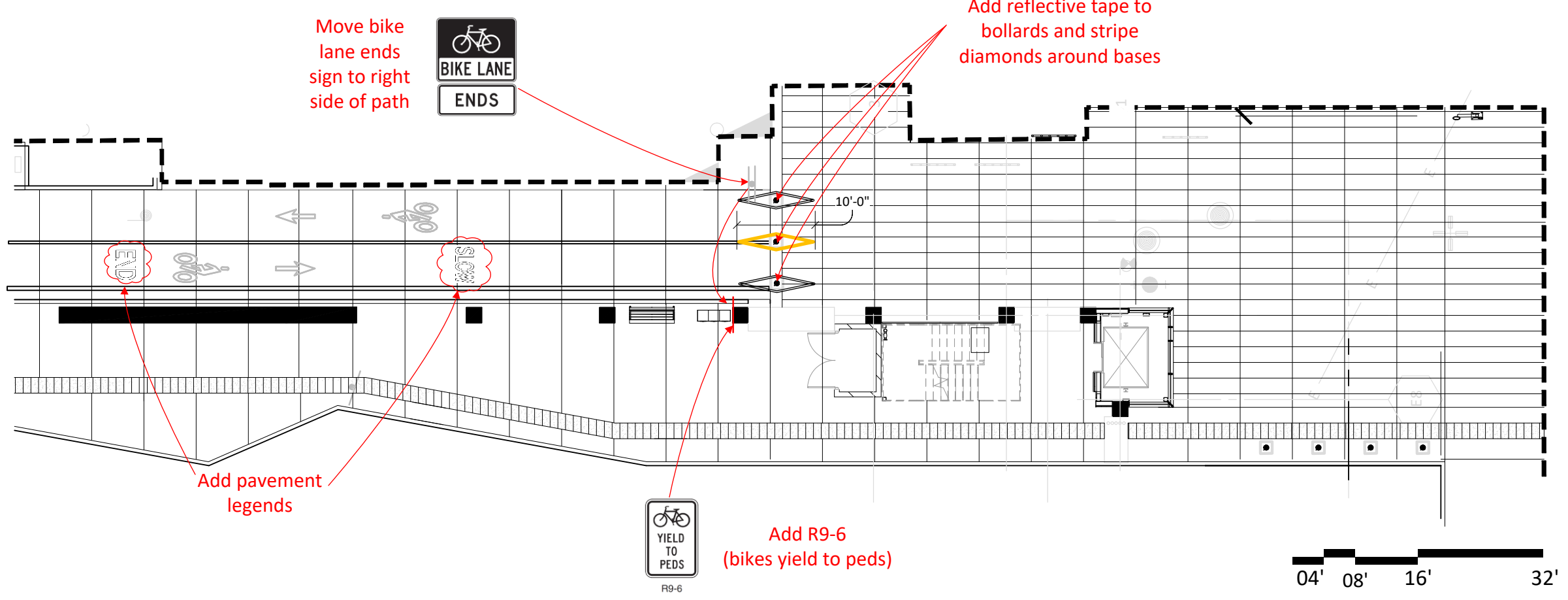
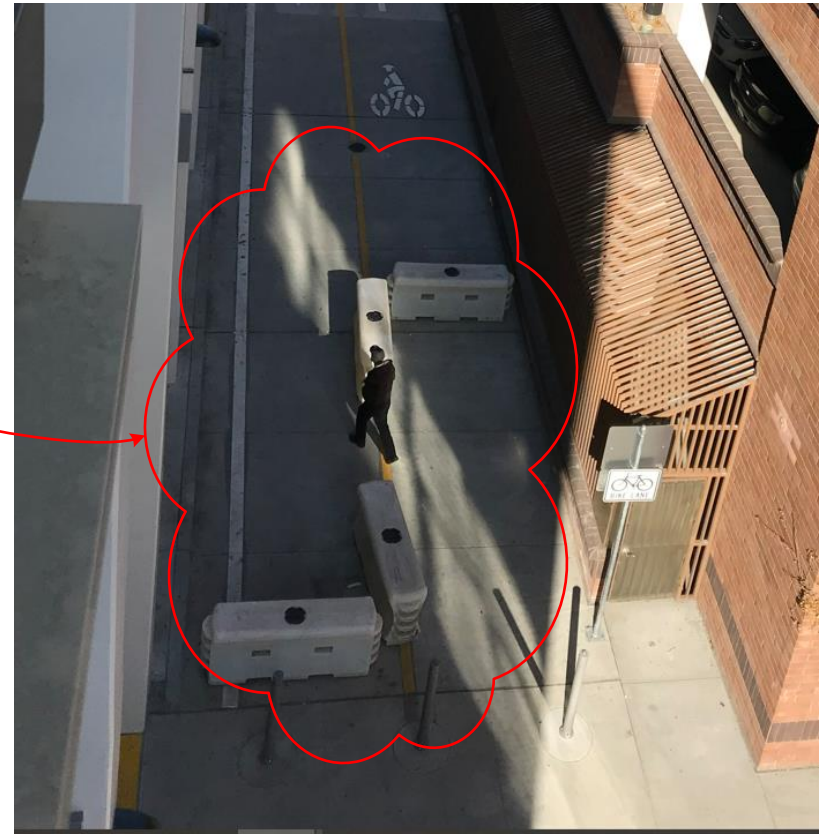
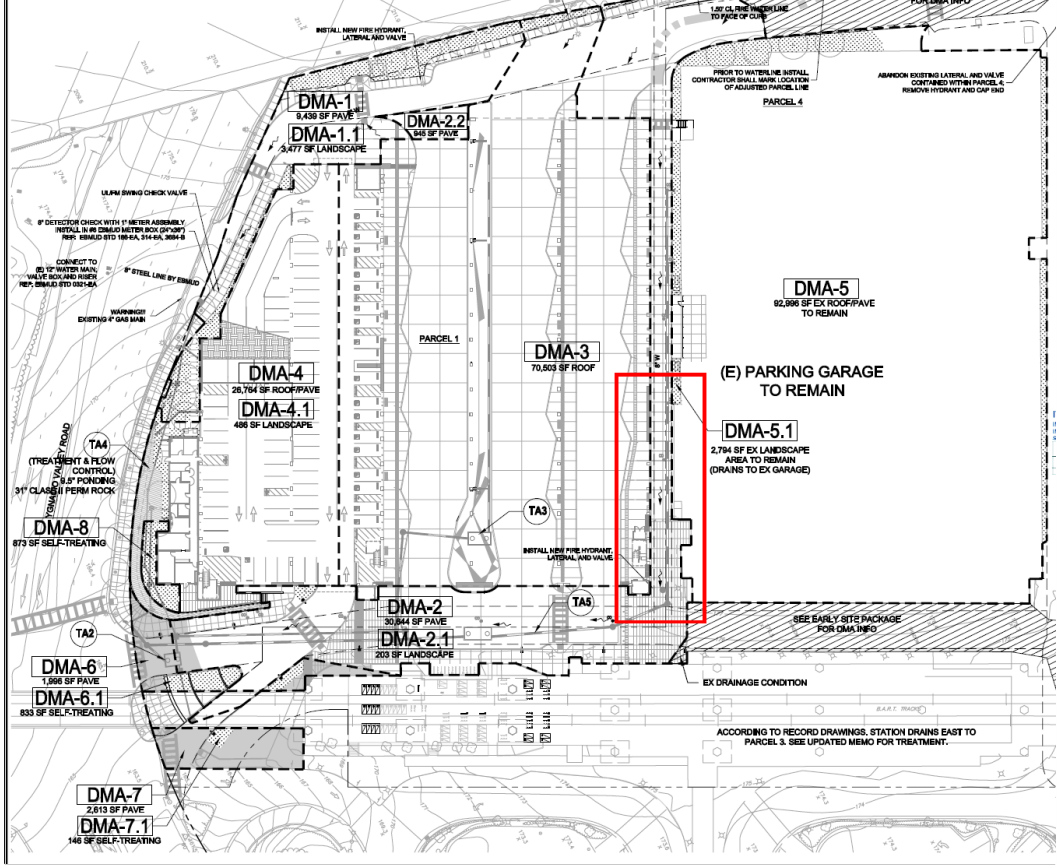

12th Street Oakland City Center
Bikeep Electronic Bike Racks
K Line -Station K10, Concourse Level

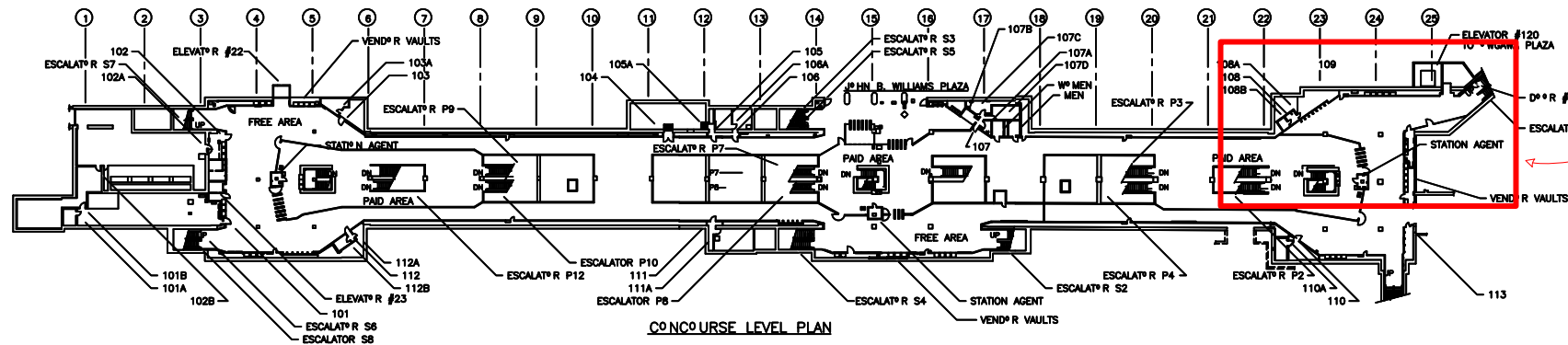

AREA OF
DETAIL

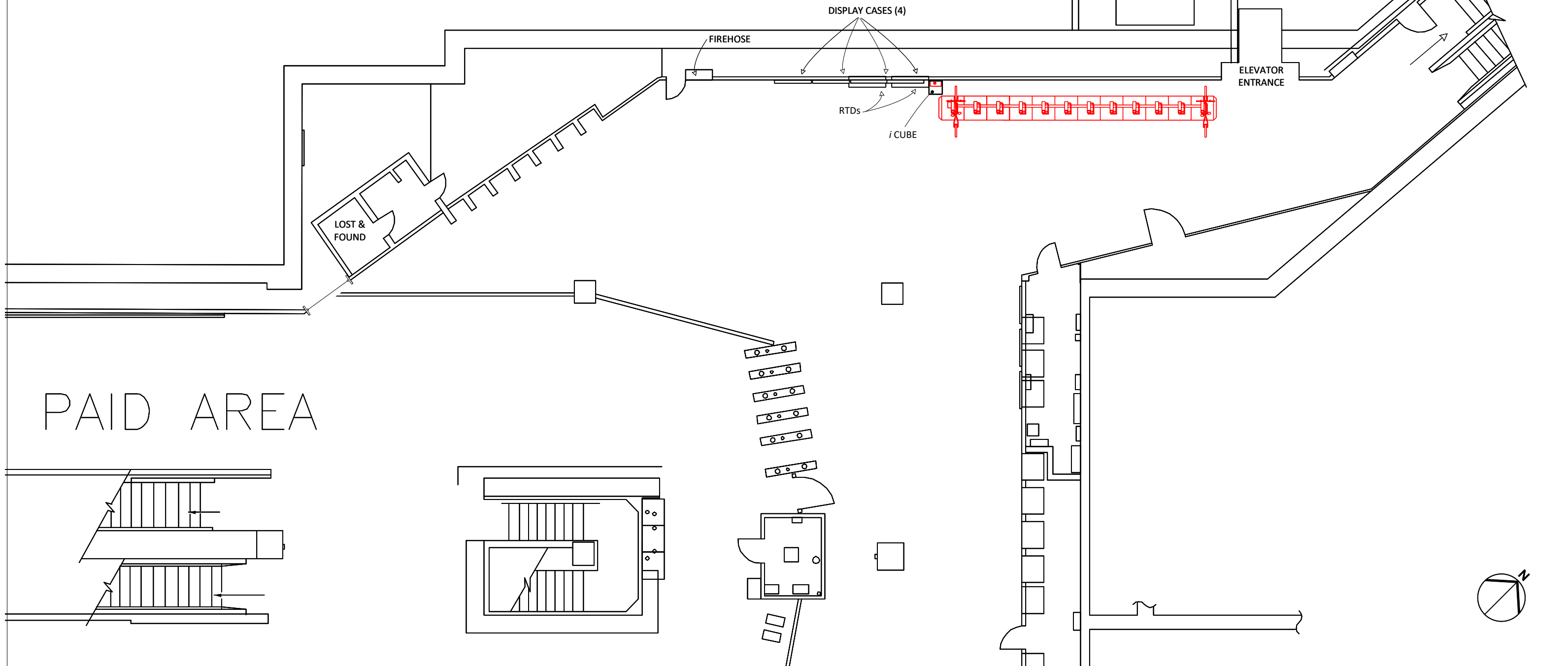

MacArthur Station

K Line - Station K30

Proposed Concourse Level Bikekeep Electronic Bike Racks

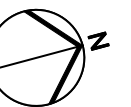
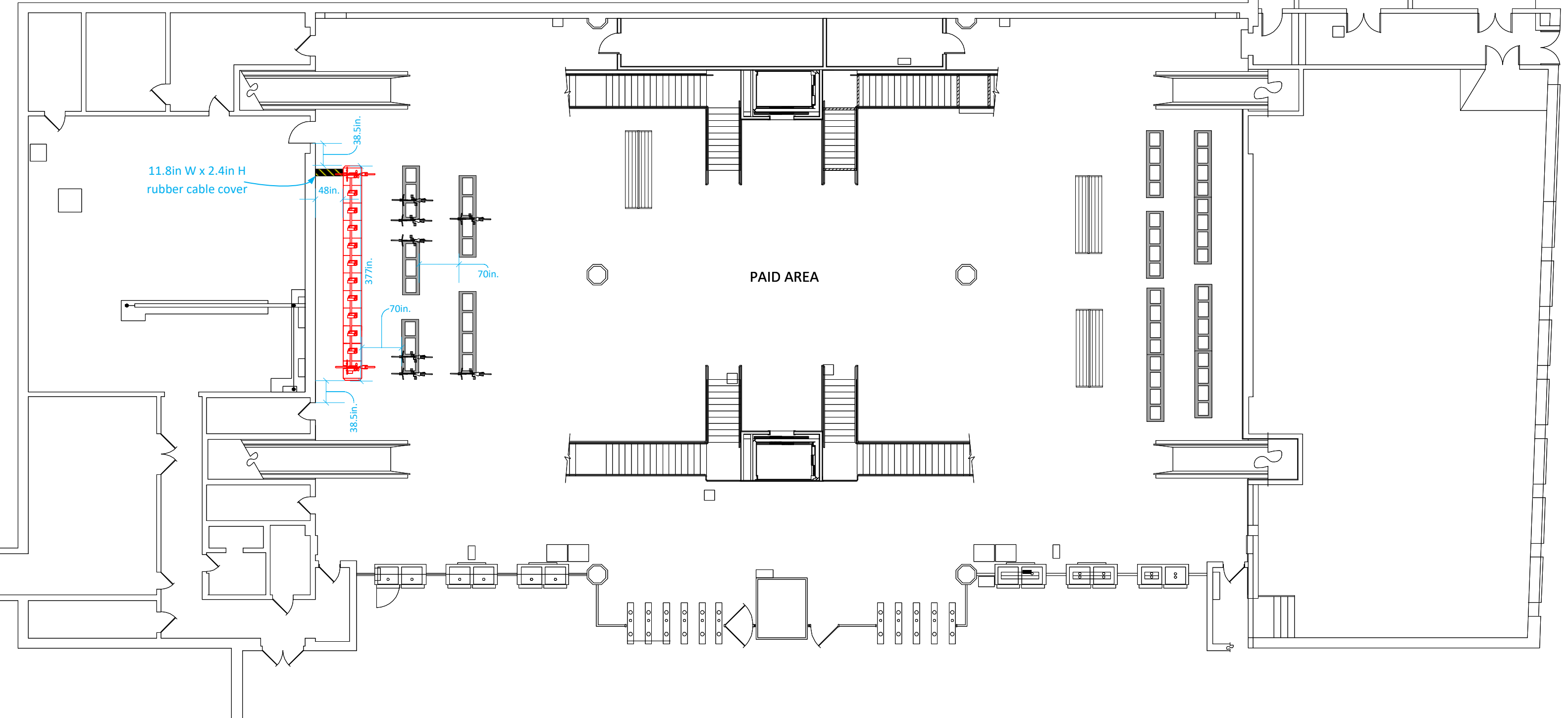

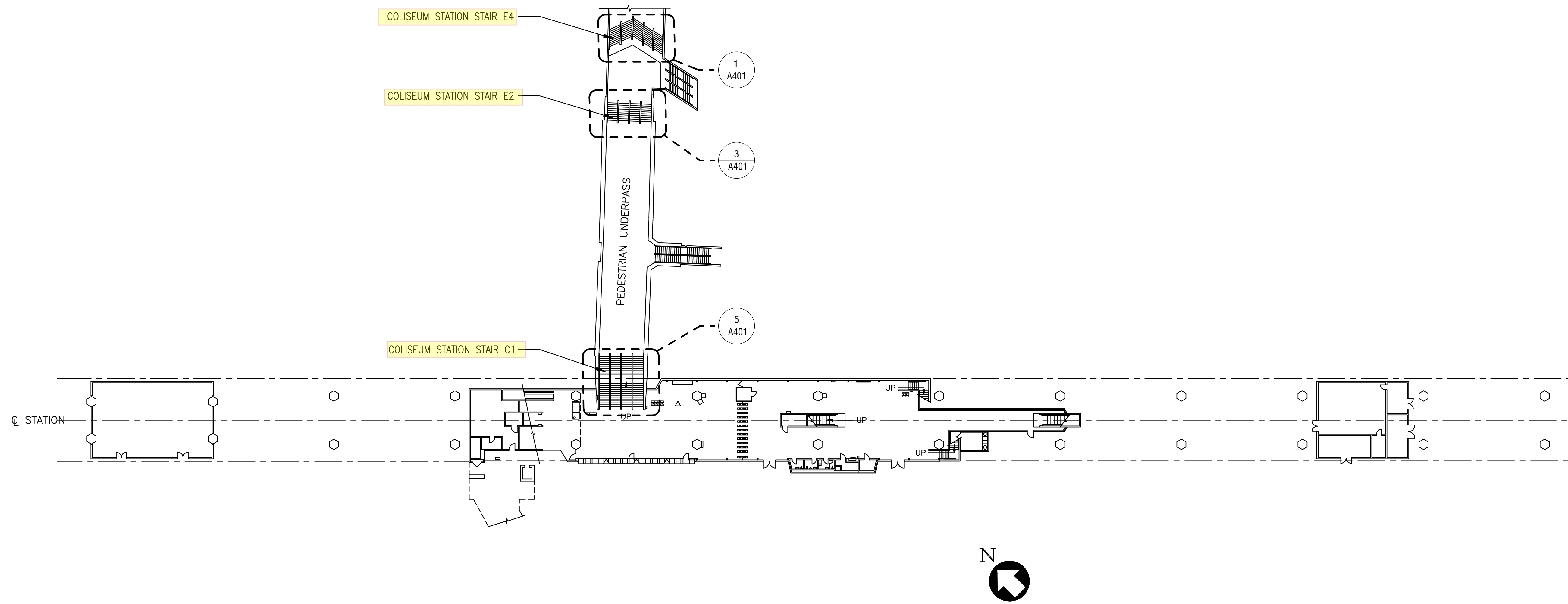

1 COLISEUM STATION KEY PLAN – CONCOURSE LEVEL
 A400 SCALE: 1" = 40'

					DESIGNED: D. LIN DRAWN: D. LIN CHECKED: D. HENMI APPROVED: D. PULTZ DATE: 10-03-2019							SAN FRANCISCO BAY AREA RAPID TRANSIT DISTRICT 		BART BICYCLE STAIR CHANNELS 2020 PHASE 1 COLISEUM STATION KEY PLAN		CADD FILENAME A_400_COLISEUM STATI...																																																									
<table border="1"> <tr><td>10/3/2019</td><td></td><td></td><td></td><td>100% CONSTRUCTION DOCUMENTS</td></tr> <tr><td>8/8/2019</td><td></td><td></td><td></td><td>90% CONSTRUCTION DOCUMENTS</td></tr> <tr><td>5/20/2019</td><td></td><td></td><td></td><td>CONSTRUCTION DOCUMENTS DRAFT</td></tr> <tr><td>2/20/2019</td><td></td><td></td><td></td><td>SCHEMATIC DESIGN DRAFT</td></tr> </table>					10/3/2019				100% CONSTRUCTION DOCUMENTS							8/8/2019				90% CONSTRUCTION DOCUMENTS	5/20/2019				CONSTRUCTION DOCUMENTS DRAFT	2/20/2019				SCHEMATIC DESIGN DRAFT						SIZE: SCALE D 1" = 40'-0"																																					
10/3/2019				100% CONSTRUCTION DOCUMENTS																																																																					
8/8/2019				90% CONSTRUCTION DOCUMENTS																																																																					
5/20/2019				CONSTRUCTION DOCUMENTS DRAFT																																																																					
2/20/2019				SCHEMATIC DESIGN DRAFT																																																																					
<table border="1"> <thead> <tr> <th>REV</th> <th>DATE</th> <th>BY</th> <th>SUB</th> <th>APP</th> <th>DESCRIPTION</th> </tr> </thead> <tbody> <tr><td> </td><td> </td><td> </td><td> </td><td> </td><td> </td></tr> <tr><td> </td><td> </td><td> </td><td> </td><td> </td><td> </td></tr> <tr><td> </td><td> </td><td> </td><td> </td><td> </td><td> </td></tr> <tr><td> </td><td> </td><td> </td><td> </td><td> </td><td> </td></tr> </tbody> </table>					REV	DATE	BY	SUB	APP	DESCRIPTION																									<table border="1"> <thead> <tr> <th>REV</th> <th>DATE</th> <th>BY</th> <th>SUB</th> <th>APP</th> <th>DESCRIPTION</th> </tr> </thead> <tbody> <tr><td> </td><td> </td><td> </td><td> </td><td> </td><td> </td></tr> <tr><td> </td><td> </td><td> </td><td> </td><td> </td><td> </td></tr> <tr><td> </td><td> </td><td> </td><td> </td><td> </td><td> </td></tr> <tr><td> </td><td> </td><td> </td><td> </td><td> </td><td> </td></tr> </tbody> </table>					REV	DATE	BY	SUB	APP	DESCRIPTION																									CONTRACT NO. 57RR-120		REV. -	
REV	DATE	BY	SUB	APP	DESCRIPTION																																																																				
REV	DATE	BY	SUB	APP	DESCRIPTION																																																																				
					SUBMITTED					APPROVED _____		CONTRACT SHEET NO. A400		PAGE NO. 014																																																											

SHEET NOTES

- 1 VERIFY ALL DIMENSIONS IN FIELD
- 2 SEE SHEET A801 FOR BIKE CHANNEL SCHEDULE
- 3 SEE SHEET A901 FOR SIGNAGE SCHEDULE

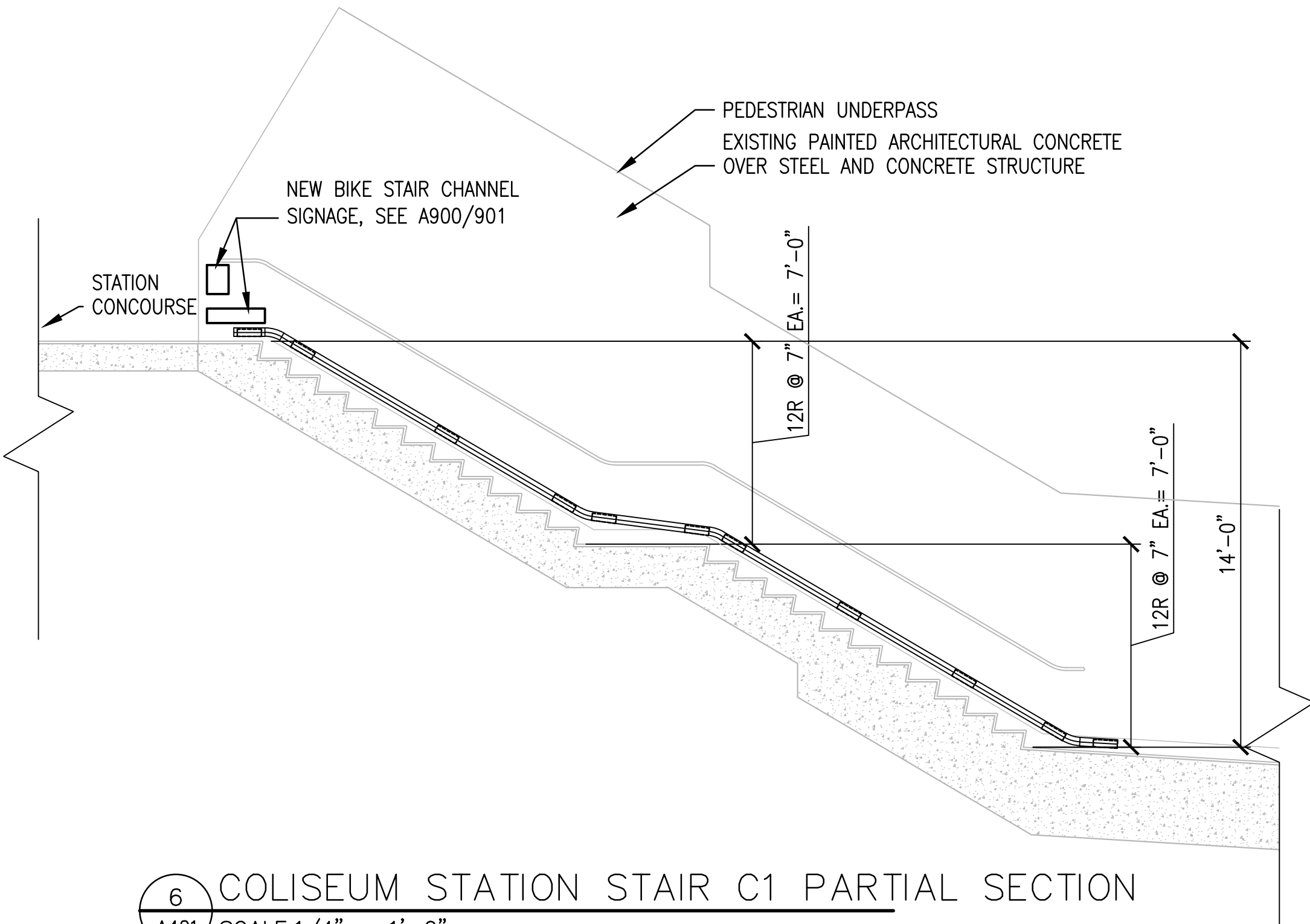

6 COLISEUM STATION STAIR C1 PARTIAL SECTION
A401 SCALE: 1/4" = 1'-0"

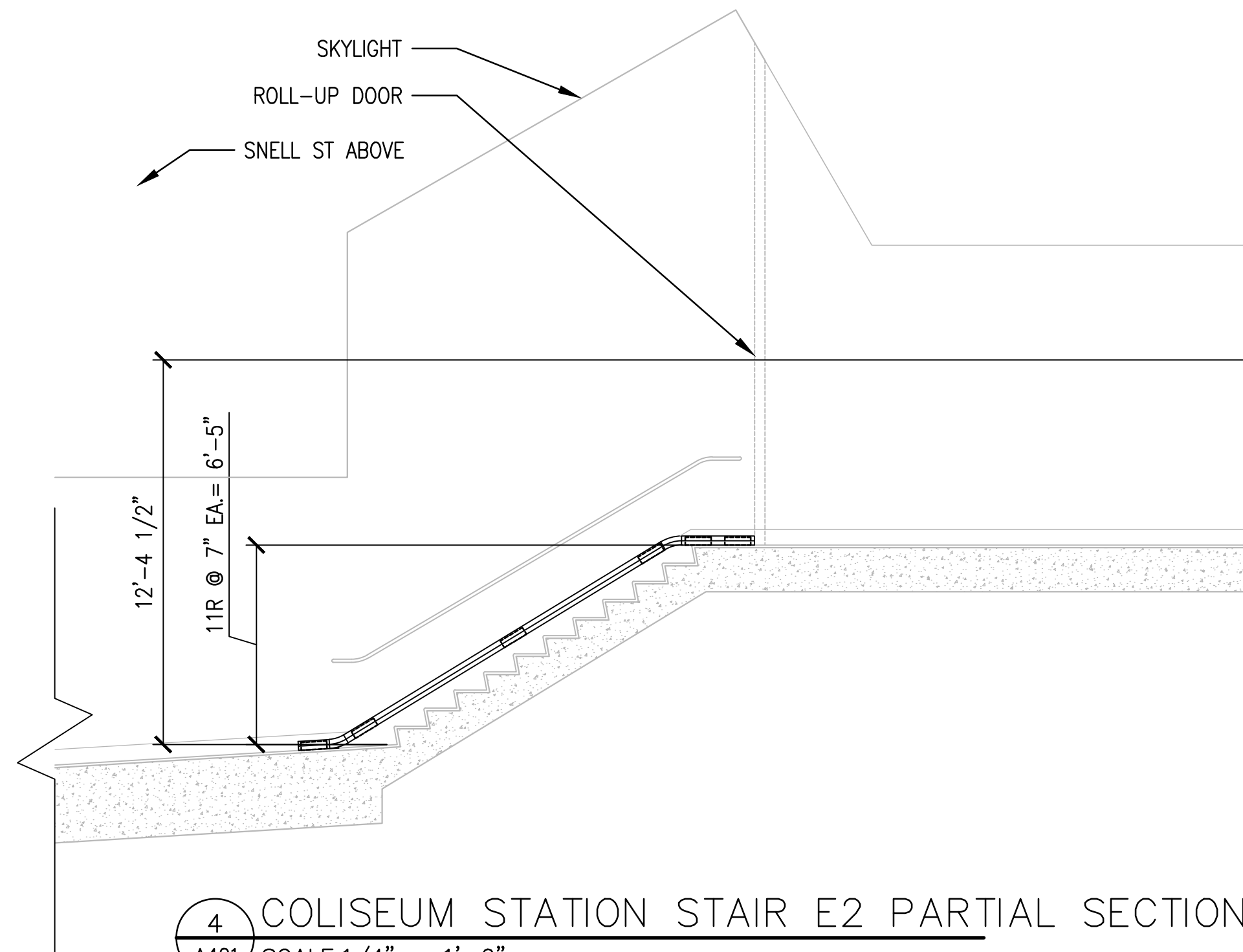

4 COLISEUM STATION STAIR E2 PARTIAL SECTION
A401 SCALE: 1/4" = 1'-0"

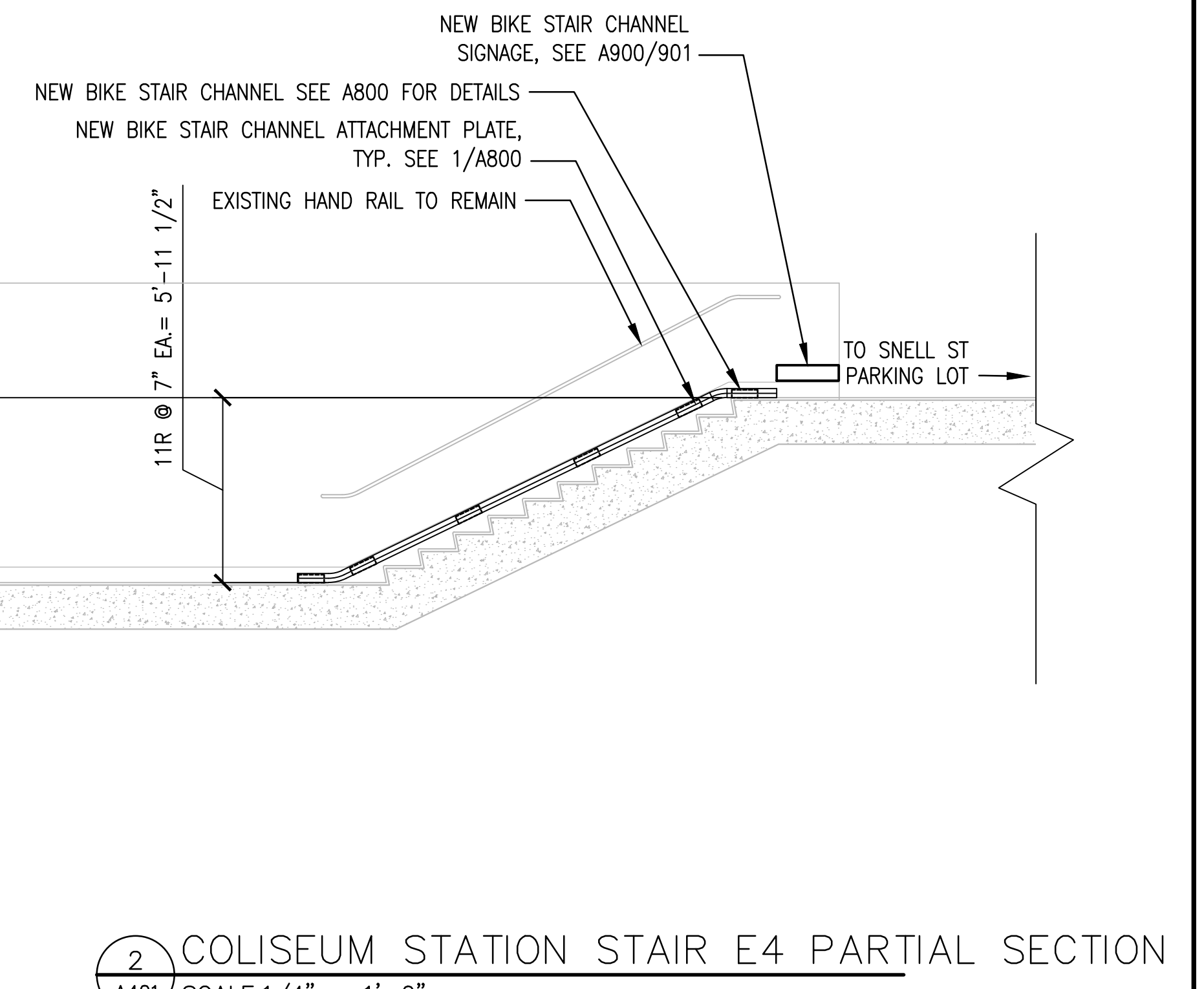

2 COLISEUM STATION STAIR E4 PARTIAL SECTION
A401 SCALE: 1/4" = 1'-0"

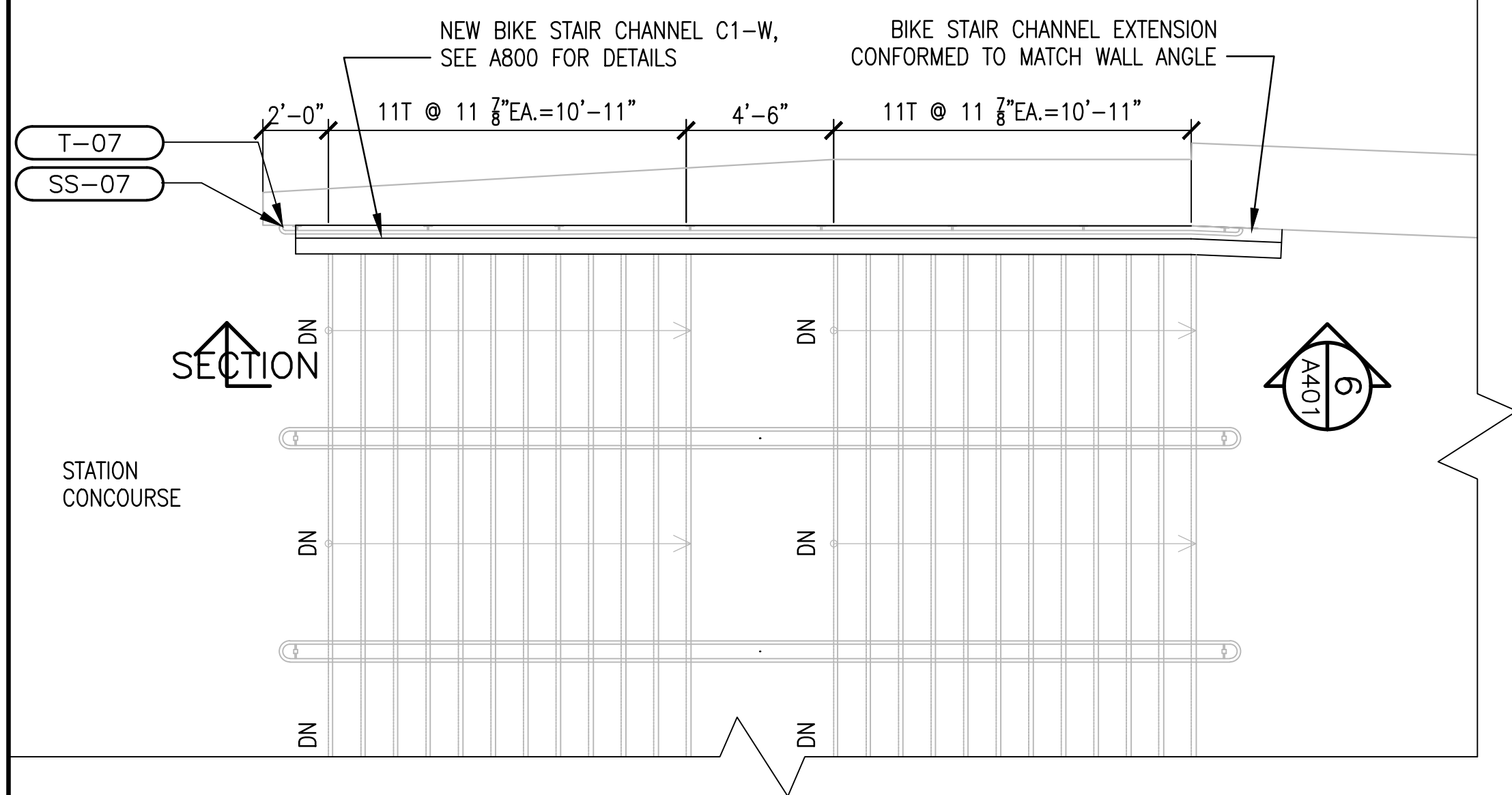

5 COLISEUM STATION STAIR C1 PARTIAL PLAN
A401 SCALE: 1/4" = 1'-0"

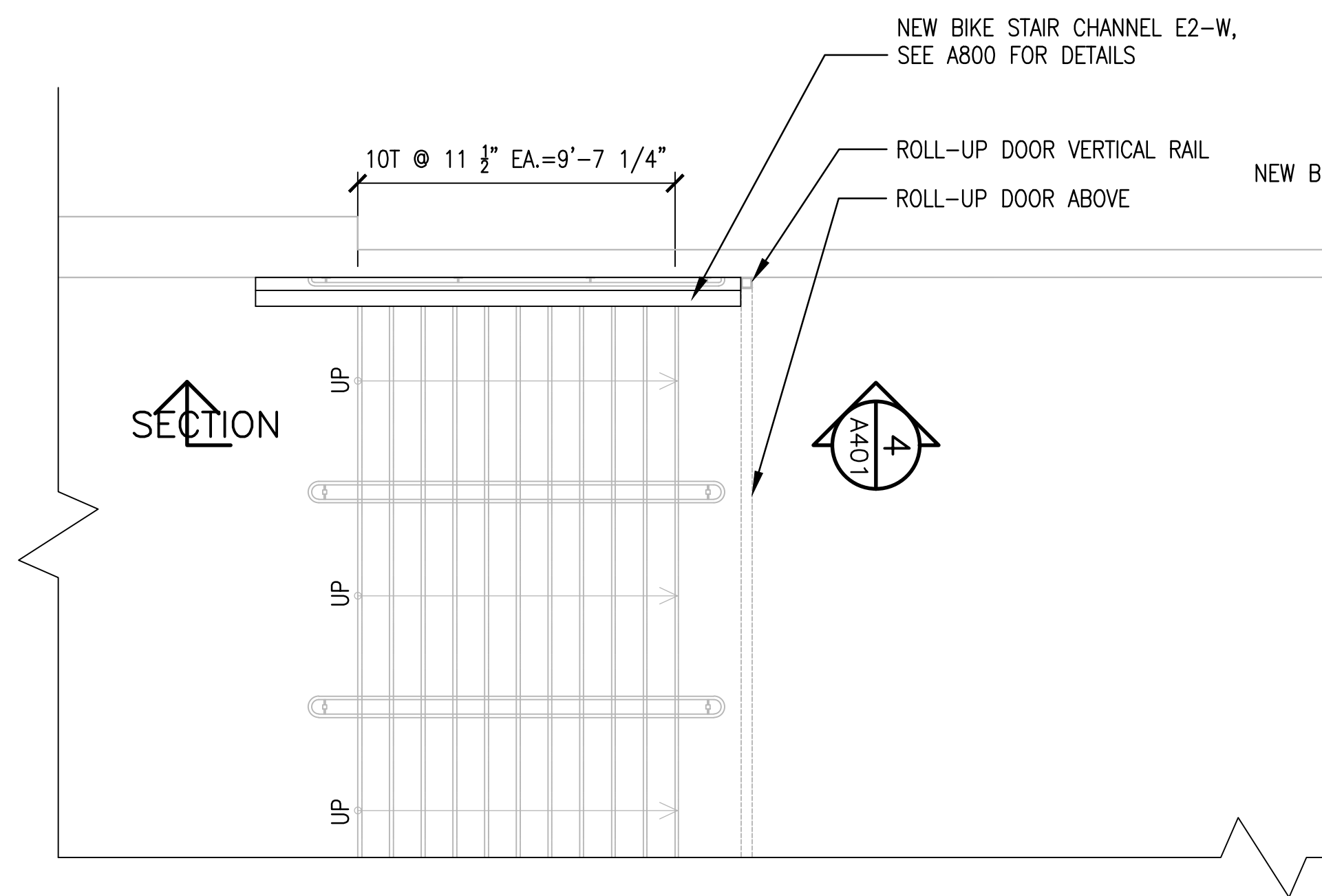

3 COLISEUM STATION STAIR E2 PARTIAL PLAN
A401 SCALE: 1/4" = 1'-0"

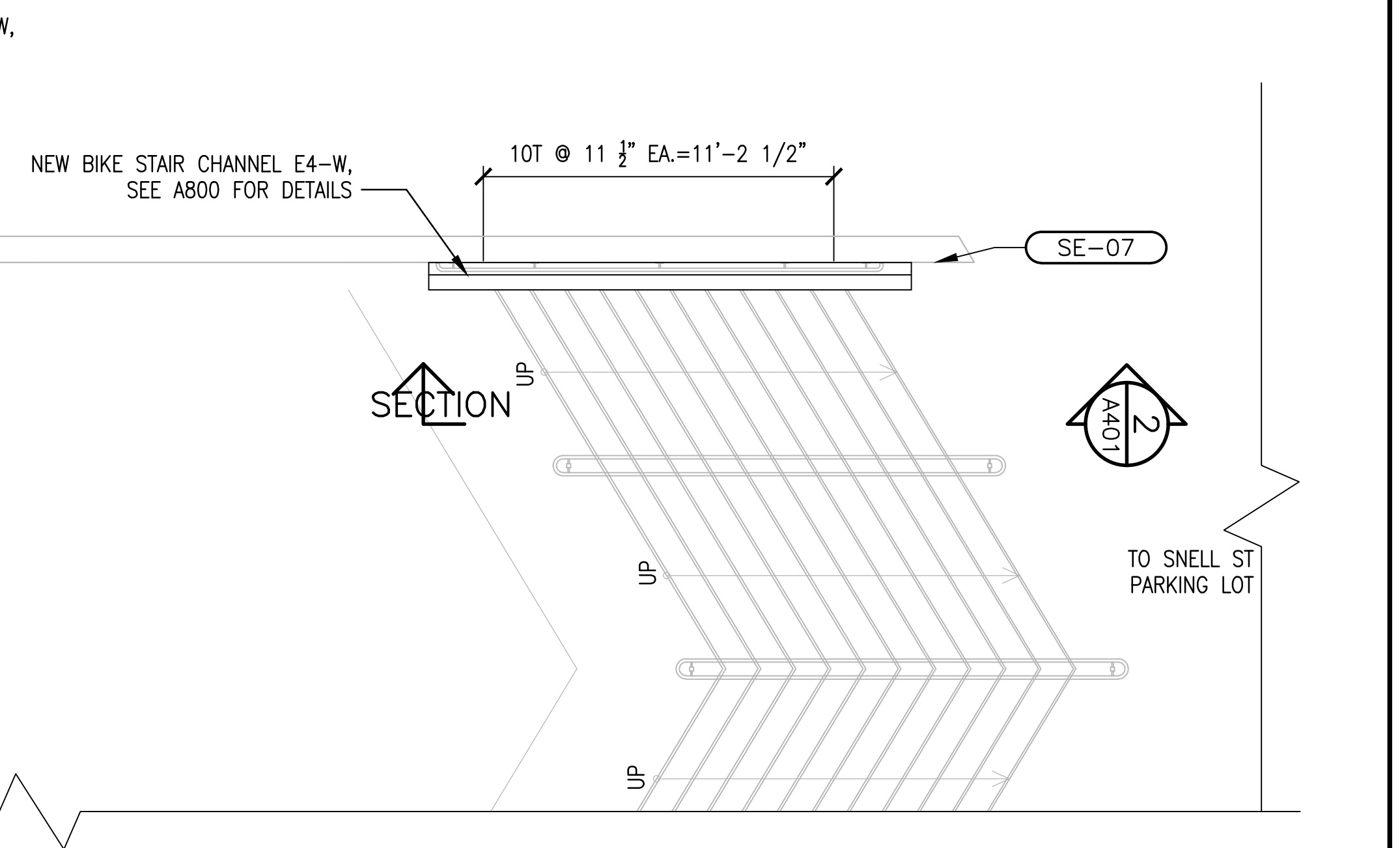

1 COLISEUM STATION STAIR E4 PARTIAL PLAN
A401 SCALE: 1/4" = 1'-0"

REV	DATE	BY	SUB	APP	DESCRIPTION	REV	DATE	BY	SUB	APP	DESCRIPTION
-	10/3/2019				100% CONSTRUCTION DOCUMENTS						
-	8/8/2019				90% CONSTRUCTION DOCUMENTS						
-	5/20/2019				CONSTRUCTION DOCUMENTS DRAFT						
-	2/20/2019				SCHEMATIC DESIGN DRAFT						

DESIGNED: D.LIN
 DRAWN: D.LIN
 CHECKED: D.HENMI
 APPROVED: D.PULTZ
 DATE: 10-03-2019

SAN FRANCISCO BAY AREA RAPID TRANSIT DISTRICT

DLR Group **HNTB**

SUBMITTED

APPROVED

BART BICYCLE STAIR CHANNELS 2020 PHASE 1

COLISEUM STATION
STAIRS C1, E2, E4 PLAN & SECTION

CADD FILENAME A_401 COLISEUM...	SIZE: SCALE D 1/4"=1'-0"
CONTRACT NO. 57RR-120	REV.
CONTRACT SHEET NO. A401	PAGE NO. 015



1 STAIR E2 & E4 – VIEW AT STREET LEVEL
A402 SCALE:NTS

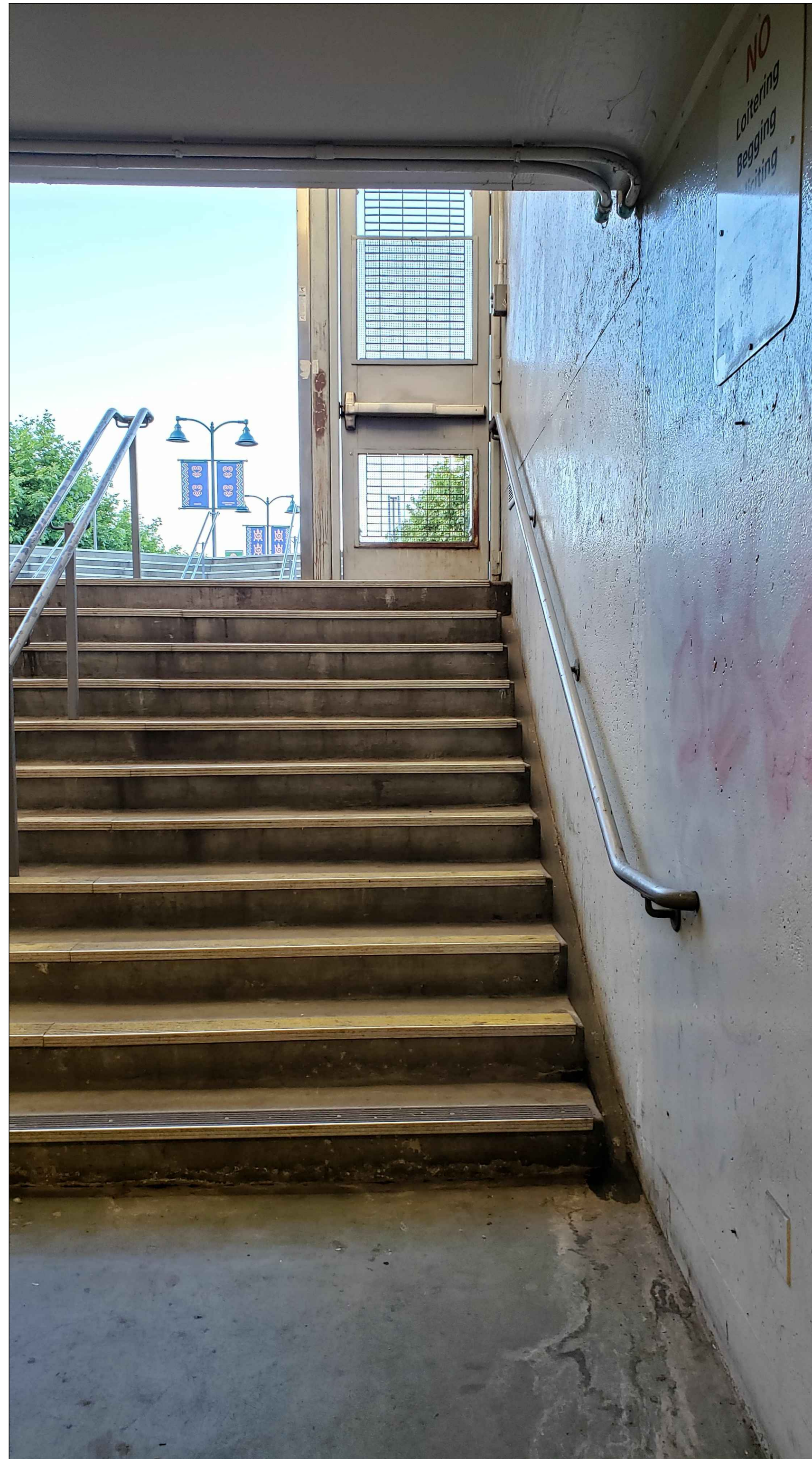

3 STAIR E2 & E4 – WALLS & CEILINGS
A402 SCALE:NTS

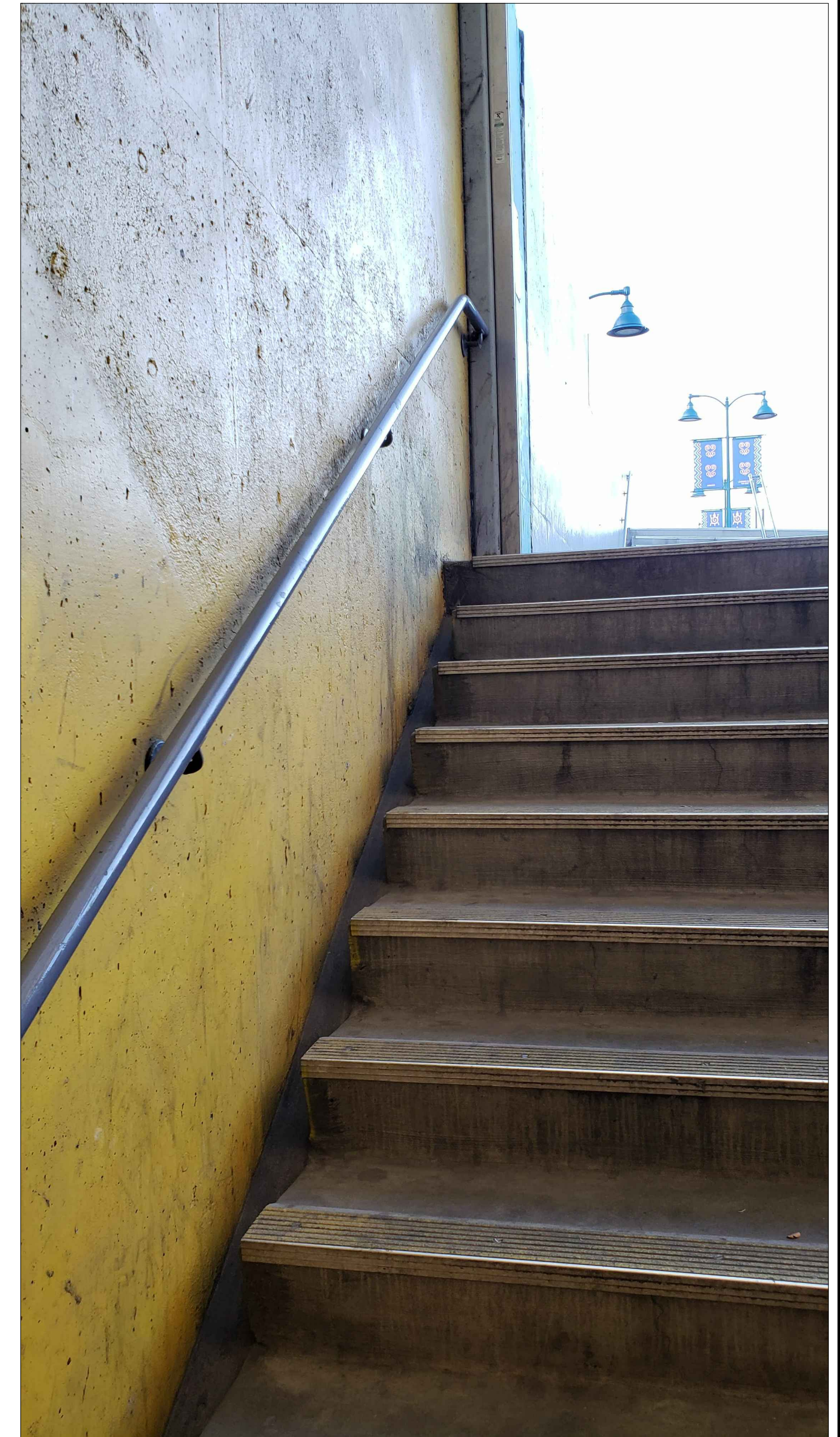

4 STAIR E2 & E4 – DRAIN
A402 SCALE:NTS

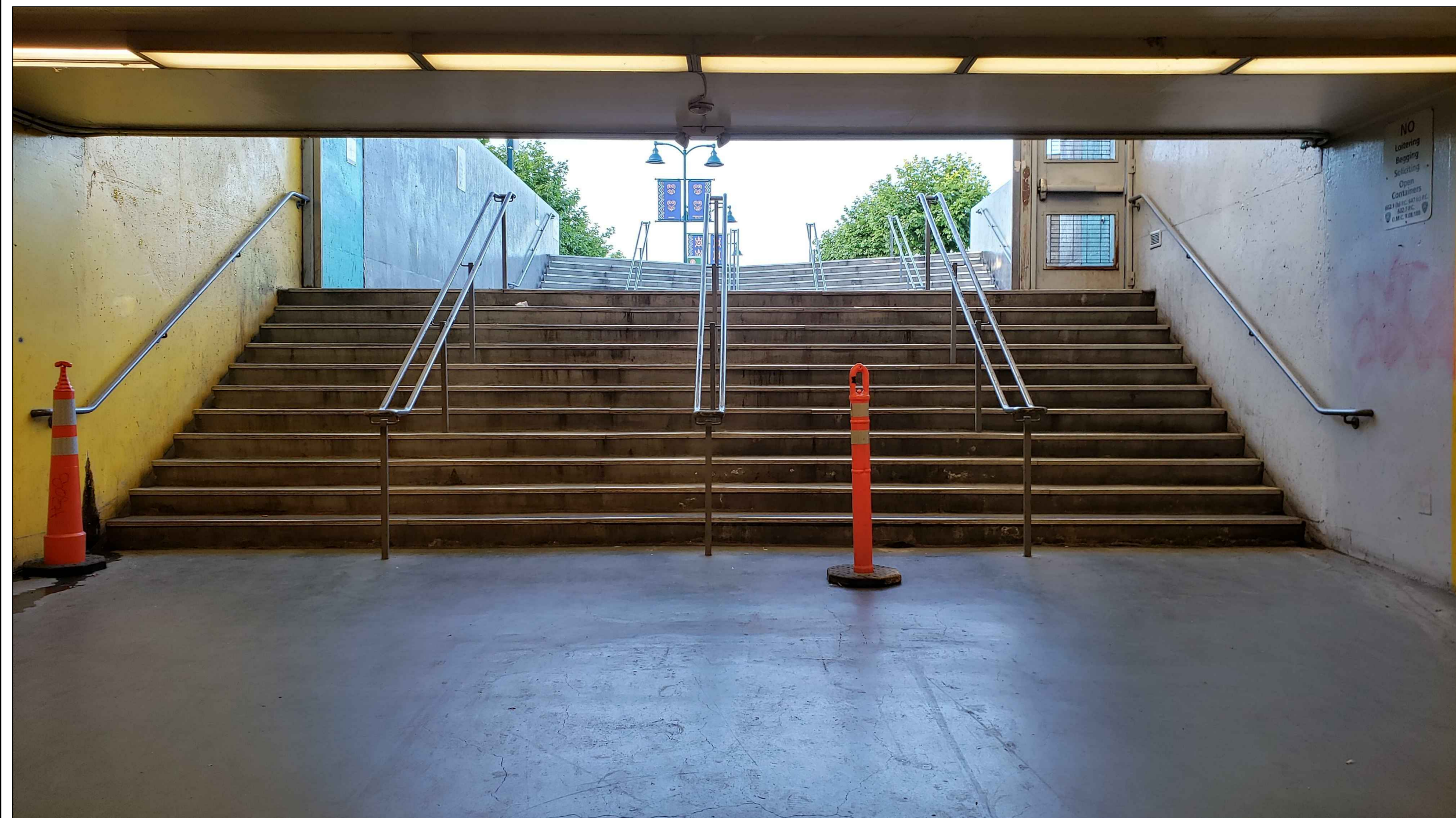

2 STAIR E2 & E4 – VIEW AT CONCOURSE LEVEL
A402 SCALE:NTS

					DESIGNED: D. LIN DRAWN: D. LIN CHECKED: D. HENMI APPROVED: D. PULTZ DATE: 10-03-2019							BART BICYCLE STAIR CHANNELS 2020 PHASE 1 COLISEUM STATION EXISTING STATION PHOTOS		CADD FILENAME NONE	
														SIZE: SCALE D NTS	
- 10/3/2019 100% CONSTRUCTION DOCUMENTS - 8/8/2019 90% CONSTRUCTION DOCUMENTS - 5/20/2019 CONSTRUCTION DOCUMENTS DRAFT - 2/20/2019 SCHEMATIC DESIGN DRAFT										CONTRACT NO. 57RR-120		REV. -			
REV DATE BY SUB APP DESCRIPTION					REV DATE BY SUB APP DESCRIPTION					CONTRACT SHEET NO. A402		PAGE NO. 016			