

SAN FRANCISCO BAY AREA RAPID TRANSIT DISTRICT
2150 Webster Street, Oakland, CA 94612, P.O. Box 12688, Oakland, CA 94604-2688
510-464-6000

NOTICE OF MEETING AND AGENDA
BART ACCESSIBILITY TASK FORCE (BATF)

October 26, 2023

2:00 p.m.

A regular meeting of the BART Accessibility Task Force (BATF) will be held on Thursday, **October 26, 2023**, starting at 2:00 p.m. to 4:30 p.m. The meeting will be held at East Bay Paratransit's location at 1750 Broadway, Oakland, California 94612, 1st Floor conference room. The facility is served by public transportation. The nearest BART Station is the 19th Street BART Station and there are multiple AC Transit routes to the meeting site.

Please note that this meeting will be held in person in the East Bay Paratransit, 1st Floor conference room, Oakland, CA 94612 with an option for public participation via teleconference.

Presentation materials will be available via Legistar at <https://bart.legistar.com>

You may attend the Committee Meeting in person or join the Committee Meeting via Zoom by calling **1-833-548-0282** and entering access code **864 2176 0151**; logging in to Zoom.com and entering access code **864 2176 0151**; or typing the following Zoom link into your web browser:

<https://us06web.zoom.us/j/86421760151>

If you wish to make a public comment:

- 1) Submit written comments via email to evanloo@bart.gov, using "public comment" as the subject line. Your comment will be provided to the Committee and will become a permanent part of the file. Please submit your comments as far in advance as possible. Emailed comments must be received before 12:00 p.m. on **October 26, 2023**, in order to be included in the record.
- 2) Appear in person and request to make a public comment.
- 3) Call **1-833-548-0282**, enter access code **864 2176 0151**, dial *9 to raise your hand when you wish to speak, and dial *6 to unmute when you are requested to speak; log in to Zoom.com, enter access code **864 2176 0151**, and use the raise

hand feature; or join the Committee Meeting via the Zoom link (<https://us06web.zoom.us/j/86421760151>) and use the raise hand feature.

Public comment is limited to two (2) minutes per person.

Please refrain from wearing scented products (perfume, cologne, after-shave, etc.) to these meetings, as there may be people in attendance susceptible to environmental illnesses.

BART provides services/accommodations upon request to persons with disabilities and individuals who are limited English proficient who wish to address Committee matters. A request must be made within one and five days in advance of Board/Committee meetings, depending on the service requested. Please contact the Office of the District Secretary at (510) 464-6083 for information.

Meeting Location

East Bay Paratransit, 1750 Broadway, Oakland, CA 94612
1st Floor Conference Room

1. Roll call of BATF members. (Information) 5 minutes
Self-Introductions: Staff and Guests.
2. Public comment. (Information)
An opportunity for members of the public to comment on items not on the agenda.
Public comment is limited to two (2) minutes per person
3. Approval of September 28, 2023 meeting minutes. 5 minutes
(Information/Action)
4. Next Generation Fare gate update. (Information/Action) 30 minutes
5. Introduction to BART Police Department Progressive Policing and Community Engagement Bureau. (Information/Action)
6. New committee member nomination. (Information/Action) 10 minutes
7. Review and approve 2024 BART Accessibility Task Force (BATF) scheduled meeting dates. (Information/Action) 10 minutes
8. Member announcements. (Information) 5 minutes
9. Staff announcements. (Information) 5 minutes
10. Chairperson announcements. (Information) 5 minutes
11. Future agenda topics – Members suggest topics.
Next meeting scheduled: November 15, 2023, Wednesday 5 minutes
December 13, 2023, Wednesday
12. Adjournment.

BATF

Approval of September
28, 2023

Meeting minutes –
AGENDA 3

SAN FRANCISCO BAY AREA RAPID TRANSIT DISTRICT
2150 Webster Street, P.O. Box 12688, Oakland, CA 94604-2688

BART ACCESSIBILITY TASK FORCE
Committee Meeting **DRAFT** Minutes
September 28, 2023

1. Roll Call of Members:

1. Anita Ortega
2. Catherine Callahan
3. Clarence Fischer
4. Daveed Mandell
5. Don Queen
6. Emily Witkin
7. Janice Armigo Brown
8. Randall Glock (Chair)
9. Roland Wong
10. VACANT
11. VACANT
12. VACANT
13. VACANT
14. VACANT
15. VACANT
16. VACANT
17. VACANT
18. VACANT

Quorum of five (5) in-person BATF members. No “Just Cause,” used.

BART Customer Access and Accessibility Department Staff:

Elena Van Loo
Matt West
Bob Franklin

BART Director (s), BART Staff, Speakers, and members of the public:

Director Robert Raburn
Ahmad Rassai (BART Staff)
Sabrina Baptiste (Staff)
Bridgett Nolot (Captioner)

Sara Hill (Captioner)
Hillary Brown (Guest)
Bruce Yow (Guest)
Jerry Grace (Guest)
Annie Koruga (Guest)
Roger Acuna (Guest)
Sarah Desumala (Guest)
Natalie Maxwell (Guest)
Danny Kodmur (Guest)
Alex Tiphayachan (Guest)
Sergio Valencia (Guest)

2. Public Comments

Danny Kodmur mentioned he attended August's BATF meeting and today will be his second meeting. He mentioned he is interested in joining the BATF.

Hillary Brown stated she is interested in joining the BATF. She mentioned this will be her third meeting that she has attended.

Annie Koruga shared correct pronouns are they/them.

Alex Tiphayachan expressed concerns that BART will no longer be selling group BART magnetic striped tickets when he teaches youth, seniors, and students with disabilities how to navigate through BART System and riding AC Transit bus system.

3. Approval of August 24, 2023 meeting minutes

Daveed Mandell moved approval of the August 24, 2023 meeting minutes with amendments. Clarence Fischer seconded the motion.

- Motion passes with seven (7) in favor, zero (0) against, and one (1) abstention

4. BART Accessibility Improvement Program – Phase 2

Ahmad Rassai (AR) presented on, "BART Accessibility Improvement Program – Phase 2."

AR introduced himself and he is the Accessibility and Improvement Program Manager. AR mentioned the purpose of the Accessibility Improvement Program (AIP) is to improve accessibility in and around the BART stations and to better meet

the needs of the disabled community and added the goal is to enhance access and safety in and around BART Stations.

He listed project locations at these BART stations.

Base Bid BART Stations:

1. Bay Fair
2. Fremont
3. Fruitvale
4. Hayward
5. MacArthur
6. San Leandro

Bid Options BART Stations:

1. Castro Valley
2. Lafayette
3. North Berkeley
4. Richmond
5. Rockridge

AR went over Accessible Improvement, Phase 2 estimated schedule for exterior work and interior work from 2023 to 2024.

He explained exterior work entails accessible ramp corrections, accessible paths and bus pad slope corrections, and cross walk stripping.

Exterior BART Stations:

1. Bay Fair
2. Hayward
3. San Leandro
4. Fruitvale
5. Richmond
6. Fremont
7. Castro Valley
8. Rockridge
9. MacArthur

AR explained interior work entails handrail corrections, replace existing courtesy phones with Americans with Disabilities Act (ADA) compliant phones, and lighting upgrades at elevator lobbies at some BART Stations.

Interior BART Stations:

1. Bay Fair
2. Hayward
3. Castro Valley
4. San Leandro
5. Fremont
6. Fruitvale
7. MacArthur
8. Rockridge
9. North Berkeley
10. Lafayette
11. Richmond

He went over a diagram of a street ramp that is Americans with Disabilities Act (ADA) compliant and would like to see ADA street ramps to be consistent throughout the BART system.

AR mentioned some handrails at BART Stations will be replaced with new ADA compliant handrails under the exterior work agreement.

He shared handset courtesy phones will be replaced with hands-free courtesy phones throughout the BART System.

Roland Wong addressed lighting concerns at South Hayward BART Station and Ashby BART Station. He said South Hayward BART Station is dark throughout the station and should add this issue to the list of improvements. He mentioned at the Ashby BART Station, the lighting at the platform level is very dim and brighter lights should be installed. AR mentioned South Hayward and Ashby BART Station are on his list for future AIP projects with lights and wayfinding signs.

Don Queen asked what does, "AIP," means. AR clarified it stands for, Accessible Improvement Program.

Don Queen stated some of the Braille Tactiles signs are too low and wishes they are located at an average human height so he does not have to bend over to touch the Braille Tactiles.

Daveed Mandell agreed with Don Queen that the location Braille Tactiles are inconsistent and stated Braille Tactiles should be metal instead of plastic.

AR mentioned federal funds have specific guidelines that BART has to follow on how the money is used. Federal funds has to be for corrective Americans with Disabilities (ADA) actions.

5. Nominations and Elections for Chair, Vice-Chair, and 2nd Vice-Chair

Elena Van Loo and Bob Franklin led agenda item, “Nomination and Elections for Chair, Vice-Chair, and 2nd Vice-Chair.”

Chairperson election:

Randall Glock was nominated as Chairperson and he accepted.

Randal Glock gave a short speech as to why he would be a good candidate as Chairperson.

Voting results for Chairperson:

- Randall Glock – eight (8) in favor, zero (0) against, Abstention (s) – one (1)

Vice-Chairperson election:

Roland Wong was nominated as Vice-Chairperson and he accepted.

Roland Wong gave a short speech as to why he would be a good candidate as Vice-Chair.

Voting results for Vice-Chair:

- Roland Wong – eight (8) in favor, zero (0) against Abstention (s) – one (1)

2nd Vice-Chairperson election:

Clarence Fischer and Janice Armigo Brown were nominated for 2nd Vice-Chairperson and both accepted.

Clarence Fischer gave a short speech as to why he would be a good candidate as 2nd Vice-Chair.

Janice Armigo Brown gave a short speech as to why she would be a good candidate as 2nd Vice-Chair.

Voting results for 2nd Vice-Chairperson:

- Clarence Fischer – three (3) in favor, zero (0) against
- Janice Armigo Brown – four (4) in favor, zero (0) against
Abstention (s) – two (2)

Elena Van Loo announced the new Chairperson is Randall Glock, Vice-Chairperson is Roland Wong, and 2nd Vice-Chair is Janice Armigo Brown and they will serve for one year.

6. New committee member nomination

Randall Glock led the agenda item and introduced Bruce Yow who is interested in becoming a BATF member.

Bruce Yow introduced himself and expressed why he is interested in joining the BATF.

Clarence Fischer moved to recommend Bruce Yow as a BATF member. Roland Wong seconded the motion.

- Motion passes with nine (9) in favor, zero (0) against, and zero (0) abstention

7. Discuss new BART September 2023 service changes

Randall Glock led agenda item, “Discuss new BART September 2023 service changes.”

Clarence Fischer mentioned he heard from people with disabilities and senior communities that they feel they are being discriminated against, especially on the Fremont and Dublin/Pleasanton lines which have six car trains. He stated people with disabilities and seniors attempt to board the trains during commute hours, some in wheelchairs, some in other mobility devices and they have been denied boarding due to the trains being packed. Clarence Fischer mentioned BART is monitoring the number of shorter trains since September 11, 2023 and may need to re-look into extending the number of trains during commute hours.

Director Robert Raburn shared BART is monitoring and depending on ongoing commute during commute hours, the number of trains can increase. He mentioned the shorter trains were to prevent anti-social behavior.

Roland Wong mentioned he has been going to San Francisco more often and has noticed the middle cars have been more packed with riders with their bikes and expressed he worries that he may catch COVID or a flu. He strongly advises to go back to ten car train during peak time.

Catherine Callahan agreed with what has been said and added the crowding on the trains really concerns her and hopes this new train service changes will be monitored. She mentioned she is a wheelchair user and entering and exiting the trains with the new train service changes has been a challenge.

Daveed Mandell mentioned he is blind and finds the six car trains to be too short. He stated he is being pushed into or trying to get around him if he's standing near the doorway and expressed his white cane, which he uses to navigate, may get damaged due to overcrowding. He says going back to eight car trains or going back to ten car trains is best thing to do.

Emily Witkin said since having shorter trains, even during non-peak hours, the trains can be too crowded heading towards to San Francisco.

8. Member Announcements

Clarence Fischer mentioned he still uses his paper discount BART tickets and mentioned as of November 30th, 2023, paper discount BART tickets will no longer be able to be used at the faregates. He asked why this was not a public announcement so people are aware of this change, deadline.

Daveed Mandell shared that Paratransit should provide same day service and making reservations twenty-four hours in advance is not acceptable.

Catherine Callahan suggested to have BART staff come to the meeting to present.

9. Staff Announcements

Bob Franklin introduced and welcomed Matt West as the new BART staff, Manager of Accessibility, in the Customer Access and Accessibility Department. Matthew West introduced himself.

Sabrina Baptiste, Office of Civil Rights (OCR), introduced herself.

Elena Van Loo mentioned travel reimbursement for the third quarter is due on October 10, 2023 and reminded members to update card numbers if they have changed.

10. Chairperson Announcements

No Chairperson announcements.

11. Future Agenda Topics – Member Suggest Topics

- Approve 2024 BART Accessibility Task Force (BATF) scheduled meetings
- New committee member nomination
 - Hillary Brown
- New generation faregates update
- Platform door markers update
- Braille within the BART System update
- Update on the number of trains in service as of September 11, 2023

12. Adjournment

The meeting adjourned at 4:09 pm until the next regularly scheduled meeting, October 26, 2023, at 2pm.

BATF

Next Generation
Faregate update –
AGENDA 4



Next Generation Fare Gate Update

BART Accessible Task Force (BATF)

October 26, 2023



Overview

- Vendor Highlights
- Fare Gate Features
- West Oakland Pilot
- Deployment Schedule



Pilot West Oakland – Construction Layout



Existing gates which will be out of service

Temporary accessible entrance/exit gates during construction

Add slide for West Oakland Prototype Gates

- STraffic has worked extensively with the ADA community and incorporated learnings into fare gate designs.



Improved Customer Experience: Accessibility

- STraffic has worked extensively with the ADA community and incorporated learnings into fare gate designs.
 - Equipped with top and side-mounted readers
 - Sensor technology for safe access of persons and service animals
 - Aisle lighting, messaging, and color-coding options



Improved Customer Experience: Patron Display

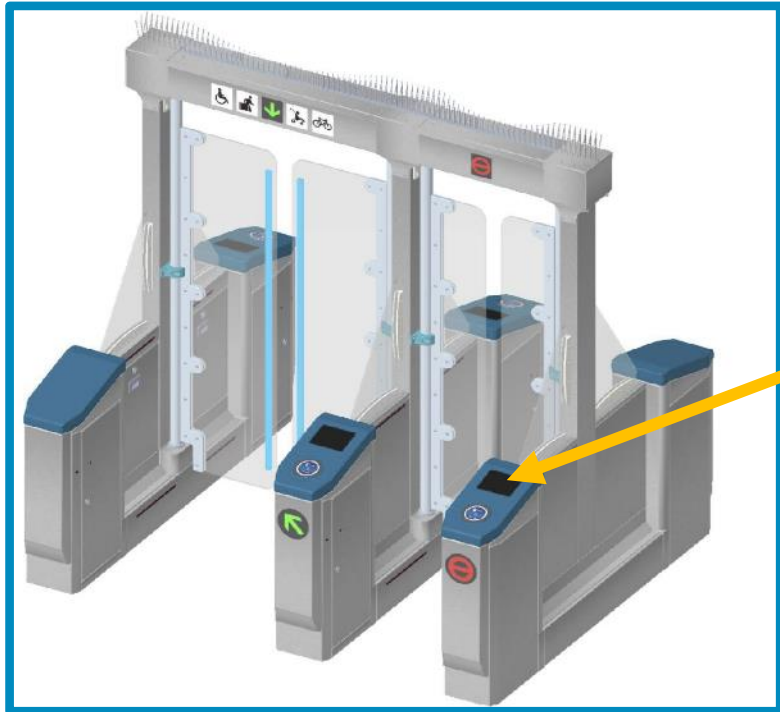

The patron display graphics are arranged in a grid-like fashion on a blue background. Each graphic is a black square with a white border, containing a white icon and text. A timestamp '9:14 AM' is visible in the bottom right corner of each graphic.

- TAP AGAIN:** A circular arrow icon.
- ADD FARE:** A white 'X' icon.
- SEE AGENT:** An icon of a person with a card.
- DO NOT ENTER:** A red circle with a white horizontal bar.
- EXIT HERE:** A green walking figure icon.
- MAINTENANCE:** An icon of crossed wrench and screwdriver.
- CARD ACCEPTED:** An upward-pointing arrow icon.

Graphics Subject to Change

Improved Customer Experience: Card Readers

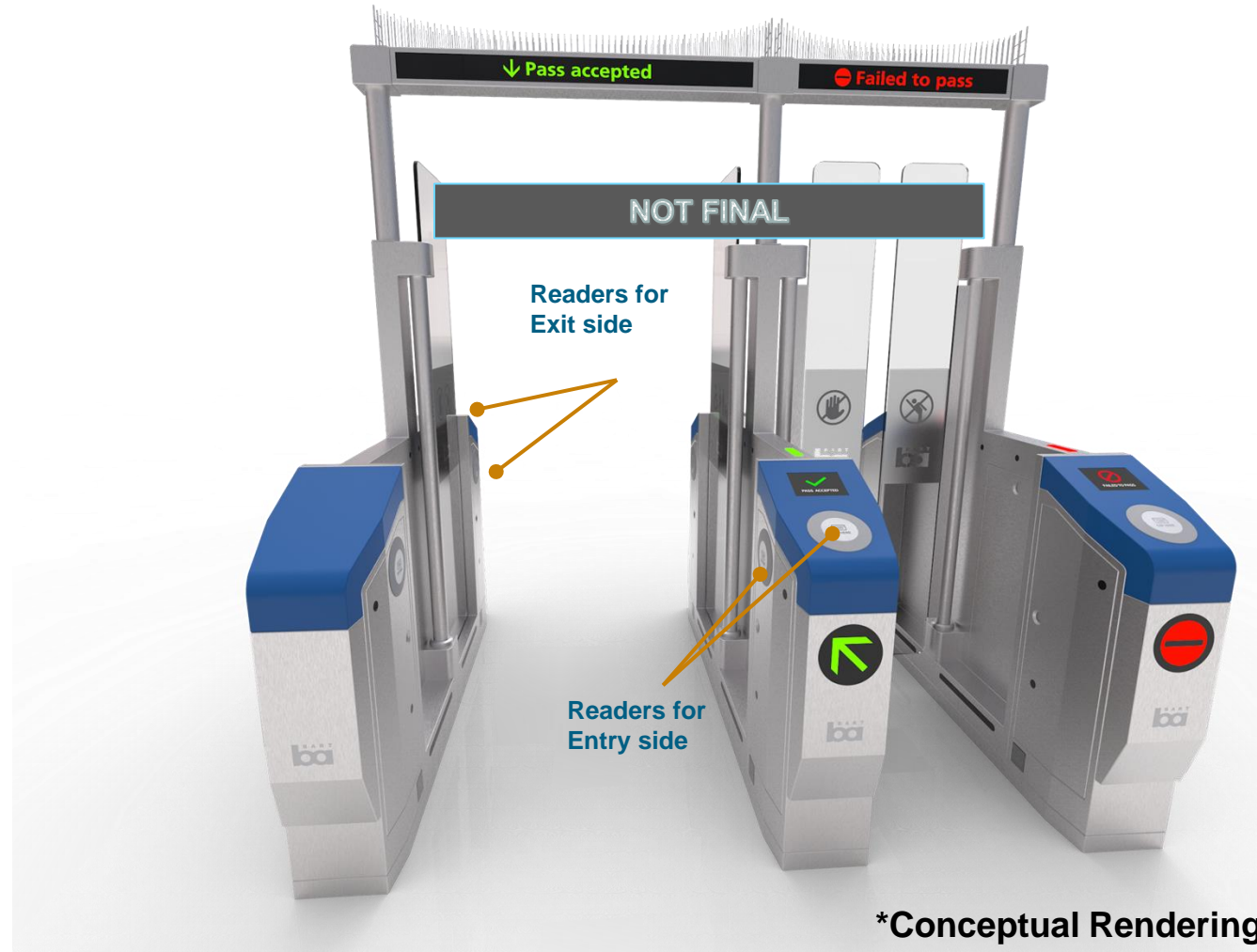

Four (4) Readers per Aisle Possible

Faregate Audio Messaging

- Used to convey faregate messages for Blind/Low Vision passengers
- Audible tones (error, successful entry,...) will remain same during initial rollout.
- New faregates will have improved sounds. We will update BATF for input in the future during systemwide rollout.



Faregate Sensors

- 16 sensors
- Detect and determine movement of passengers (authorized and unauthorized) between the free and paid areas.

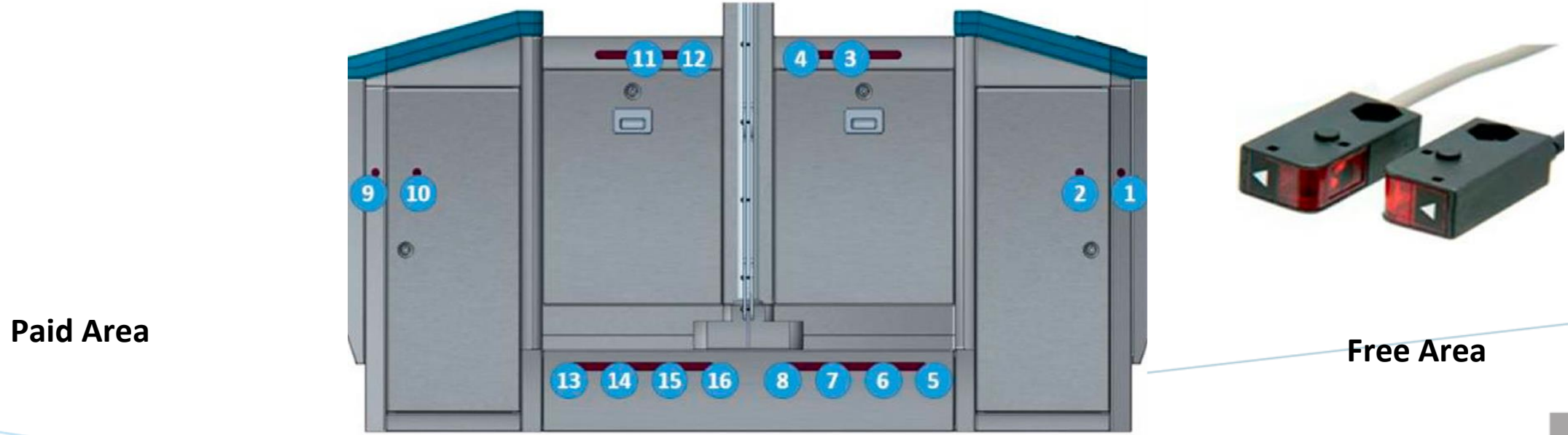

AI Camera

- Installed in the overhead bridge

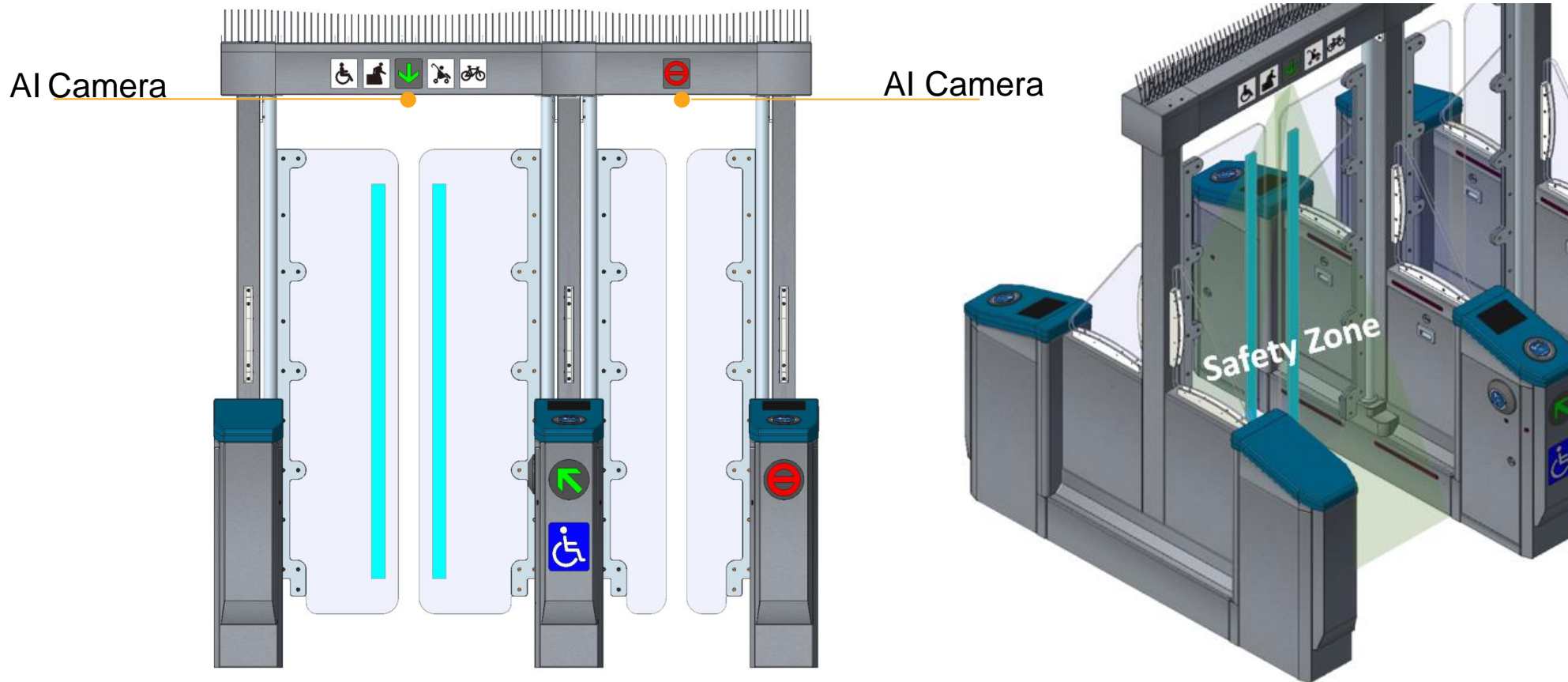

Detect - Advanced Sensor Technology

- ✓ Infrared
- ✓ 3D Sensor
- ✓ Camera

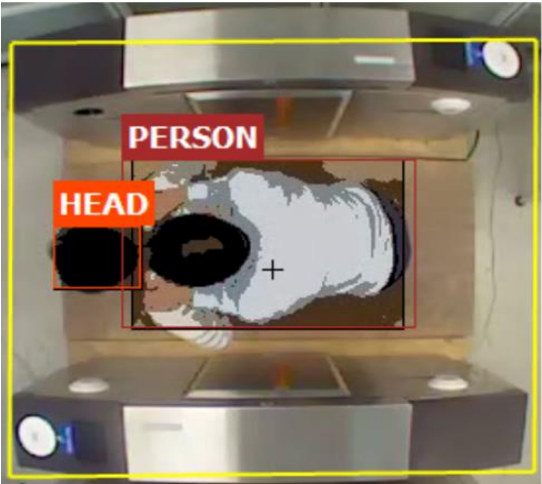

Piggybacking

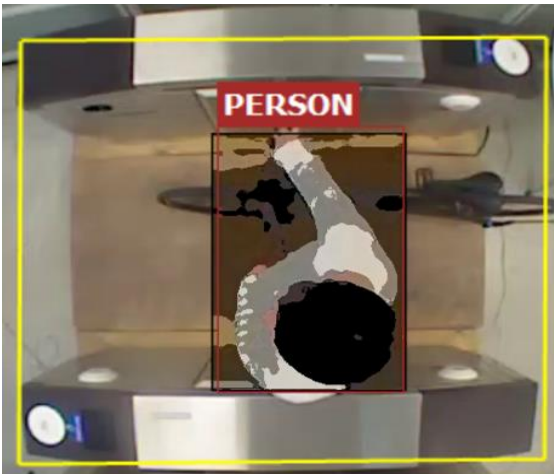

Bicycle

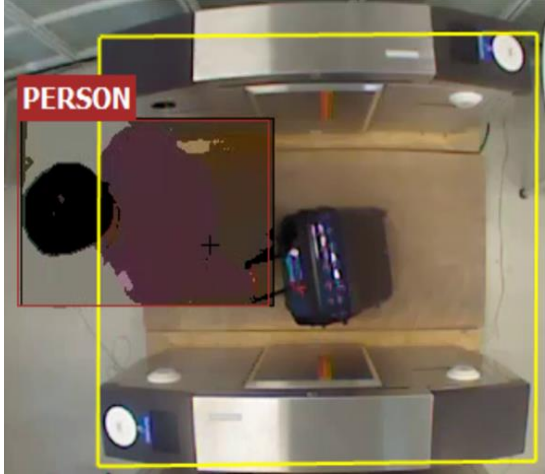

Luggage

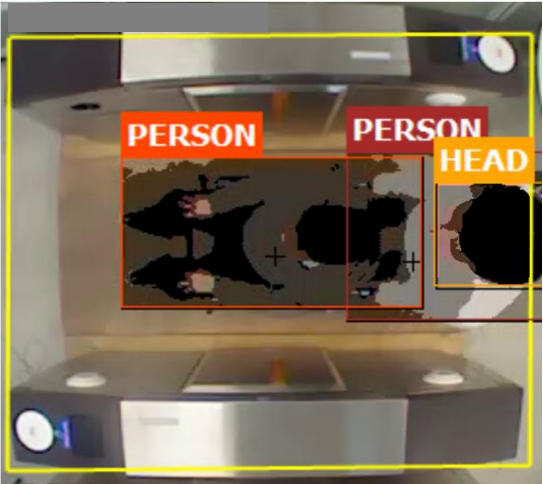

Wheelchair (2 persons)

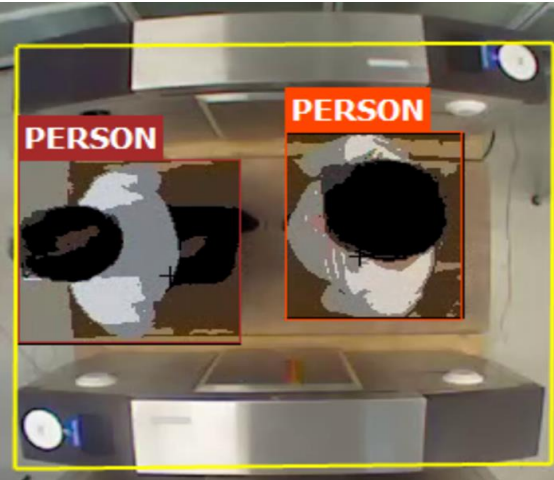

Tailgating



No facial recognition

Next Generation Initial Deployment Schedule

Subject to change

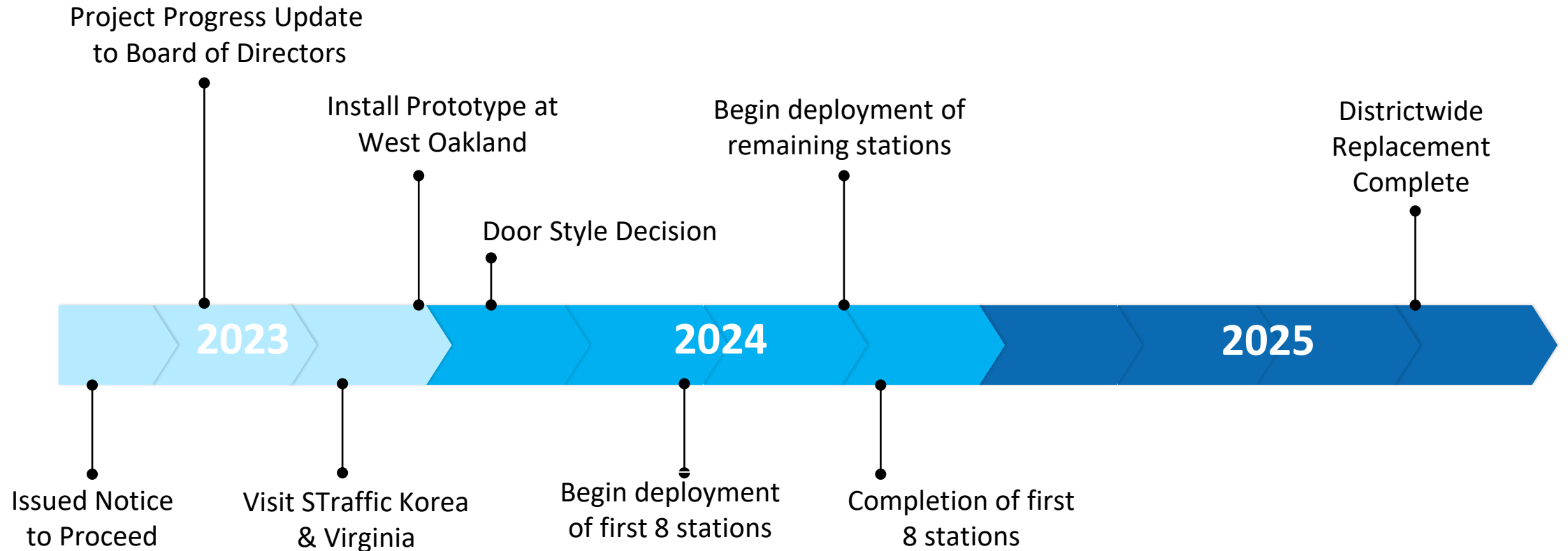

Questions?

BATF

Introduction to BART's PD Progressive Policing and Community Engagement Bureau – AGENDA 5



Let's go.

GET TO KNOW

BART PD's Progressive Policing and Community Engagement Bureau

Dear BART rider,

Your safety is BART's top priority. The voices of riders like you are why the BART Police Department created the new Progressive Policing and Community Engagement Bureau. This initiative represents a bold approach to public safety that recognizes not every problem on BART requires a response by a police officer. The Bureau utilizes a mix of sworn and civilian BPD staff to bolster the department's visible presence in the system while offering more appropriate ways to respond to a range of calls for help.

"We're here for the community and we'll go on this journey with them."

– Progressive Policing and Community Engagement Bureau Leader Ja'Son Scott

Why a Progressive Policing Bureau?

BART Police Chief Ed Alvarez's vision for safety includes making BPD the most equitable law enforcement agency in the nation. Alvarez created the Bureau in 2020 to lead the way with new approaches to address systemic societal issues affecting public safety, including homelessness, mental illness, and addiction. Extensive community meetings were held with overwhelmingly positive responses to this approach from those who attended. Deputy Chief Ja'Son Scott, who has extensive experience in community outreach, leads the Bureau.



Above: BART Deputy Police Chief Ja'Son Scott and Police Chief Ed Alvarez

What makes the Bureau different?

BPD is among the first transit policing agencies in the country to create a Progressive Policing Bureau. Utilizing unarmed personnel such as Transit Ambassadors and Crisis Intervention Specialists boosts the visible safety presence on trains and in stations while ensuring BART is welcoming to all riders. By responding to hundreds of calls every month unarmed BPD staff also free up sworn officers for situations when a traditional police response is appropriate.

Transit Ambassadors and Crisis Intervention Specialists work with sworn officers in the Progressive Policing Bureau. They all wear special, dressed-down uniforms and work in Special Engagement Teams (SET) together throughout the BART system.

Transit Ambassadors

Provide presence and visibility on trains, platforms, and at stations. They're equipped with masks, Narcan (to respond to drug overdoses), and a police radio. They walk more than a dozen trains and stations on a typical shift.



Crisis Intervention Specialists

Have a background in social work and assess people experiencing mental health and other kinds of crises, including housing insecurities. Their focus is to connect people in crisis with support services.

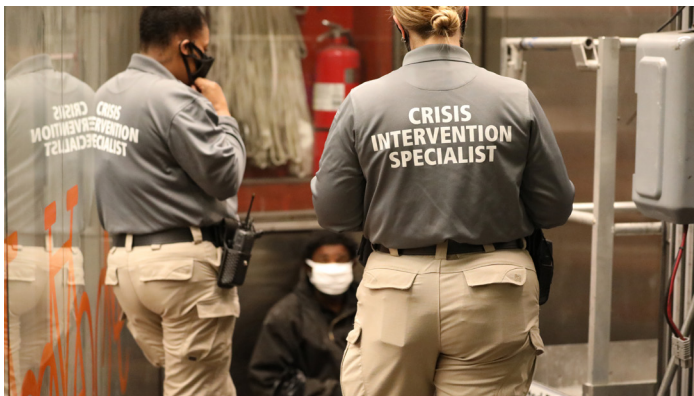

If You See Something Say Something™

- Download the BART Watch app. Use it to discreetly report any concerning situation.
- Text BPD Dispatch at (510) 200-0992
- Call BPD by phone at (510) 464-7000
- Use the train intercom to speak with the train operator; use a white emergency phone in the station; or speak to any uniformed BART staff.



Tips for contacting BPD

- If you see someone in distress who might need medical attention or is experiencing a crisis, contact BPD dispatch to request a welfare check. If aboard a train, look for the car number at each end of the vehicle. If you're on a platform, look for signage to indicate the nearest entrance. Share as many specific details as possible with the police dispatcher. Members of the Progressive Policing Bureau are specially trained to respond to people in crisis.
- If you see a situation that could be dangerous, avoid engaging with anyone who is acting in a threatening manner. Try to move to a safe location to contact BPD. You can use the BART Watch app or text BPD to report something discreetly without making a phone call.

Resources to Learn More

Read about a decade-plus of reforms at BART Police at bart.gov/police reforms

BART has one of the most rigorous police oversight models in the country that includes both an Office of the Independent Police Auditor and a Citizen Review Board.

- Visit bart.gov/police auditor and bart.gov/crb
- Read how you can help end gender-based violence at bart.gov/NotOneMoreGirl
- Practical safety tips at bart.gov/safety
- Contact info for dozens of community resources in BART's service area at bart.gov/resources

BATF

New committee
member nomination –

AGENDA 6

**BART ACCESSIBILITY TASK FORCE (BATF)
MEMBERSHIP APPLICATION FORM**

Name of applicant: Hillary Brown

3. EXPERIENCE AND SKILLS

3.a. Names and purposes of boards, commissions, or task forces you currently serve on or have served on and its relevancy to serving on BART's Task Force (BATF). Please indicate dates of service and the positions you held, if any:

- Currently serve with MAAC (Multimodal Accessibility Advisory Committee), San Francisco, CA
- Currently serve with Geary CAC (Geary Community Advisory Committee), San Francisco, CA (serve people with disability communities)
- Currently serve with PROSAC (Parks Recreation Open-Space Advisory Committee) – District #5

3.b. Why do you want to serve on and what skills do you bring to the BART Accessibility Task Force (BATF):

Would like to advocate further from San Francisco area and be more exposed East Bay area. Advocate for people with disabilities, especially people with visual impairments

3.c. How would your membership assist in establishing communication with the disability community:

Having more diversity amongst race, especially people who are African American just like me.

Signature of Applicant: Hillary Brown

Date: 10/3/2023

BATF

Review and approve
2024 BATF scheduled
meeting dates –

AGENDA 7

2024

BART Accessibility Task Force (BATF)

Regular Schedule Meeting Dates

Regular monthly meetings dates of the **BART Accessibility Task Force (BATF)** shall be held every fourth Thursday of each month, with the exception for the months of November and December 2024, due to holidays. BATF meetings will be held in-person for appointed BATF members and Teleconferencing will be available for the members of the public and presenters.

1. **January 22, 2024** - Thursday
2. **February 26, 2024** - Thursday
3. **March 25, 2024** - Thursday
4. **April 22, 2024** - Thursday
5. **May 27, 2024** - Thursday
6. **June 24, 2024** - Thursday
7. **July 22, 2024** - Thursday
8. **August 26, 2024** - Thursday
9. **September 23, 2024** - Thursday
10. **October 28, 2024** - Thursday
11. **November 10th** (2nd Wednesday) or 17th (3rd Wednesday), 2024
12. **December 8th** (2nd Wednesday) or 15th (3rd Wednesday), 2024

- Numbers 1 through 11, BATF meetings will be held at, East Bay Paratransit, 1750 Broadway, 1st Floor conference room, Oakland 94612
- Meeting location will be announced at a later date for December's schedule BATF meeting

Note: All BATF meetings starts at 2:00 pm and end around 4:30pm